

Hydraulic lift crane

LR 1110

EN

LR 1001.02



LIEBHERR

Concept and characteristics



LR 1110 Standard

- Excellent lifting capacities thanks to optimized distribution of forces
- New cabin with improved and ergonomic operating concept
- Convenient ladder to access the cabin
- Optimized air-conditioning and airflow in the cabin
- Catwalks and optional railings on uppercarriage and cabin
- Transport possible with mounted boom foot and crawlers
- Foldable catwalks remain with the machine during transportation
- Optional railings can be disassembled in a few steps using pin connections



Option: LR 1110 with swinging counterweight

- Up to 20% increase in lifting capacities where tilting is the limiting factor
- Larger radii thanks to improved stability
- Function of swinging counterweight: the rear counterweight splits in the centre and is swung backwards to a max. angle of 90°. The counterweight can adopt any position within this angle range. The optimized lifting capacities are calculated online in real time via the LMI system and displayed in the operator's cab.
- Easy and quick adaptation of the counterweight to the lifting requirements
- Swinging counterweight requires less counterweight – swinging back leads to improved ground pressure and similar lifting capacities to those with full counterweight in standard position can be achieved.
- Swinging the counterweight back makes the machine narrower – this allows the machine to pass through narrow spaces.
- For increased lifting capacities the swinging counterweight can also be added to other LR 1110 with standard counterweight

Dimensions

Basic machine with undercarriage

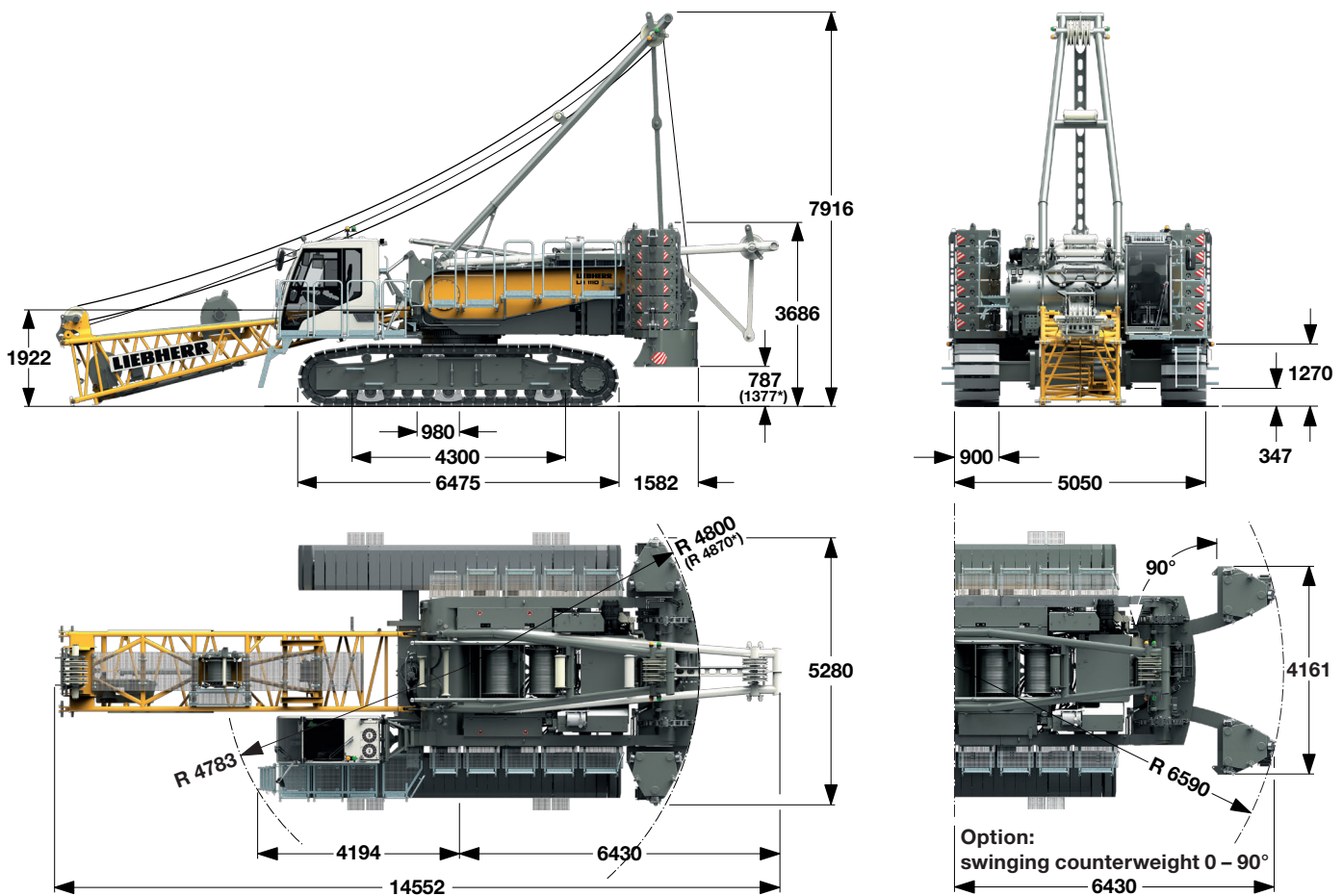

*) with standard counterweight

Operating weight

The operating weight includes the basic machine with crawlers, 2 main winches 120 kN and 14 m main boom, consisting of A-frame, boom foot (7 m), boom head (7 m), 34 t basic counterweight, 17.5 t carbody counterweight and 100 t hook block.

Total weight _____ approx. 115.6 t

Ground pressure

The actual ground pressure is calculated according to the configuration and position of the machine and displayed in the operator's cab. Using the optional Liebherr Crane-Planner the actual ground pressure, amongst other parameters, can already be calculated and displayed in the planning stage.

Equipment

Main boom (No. 1512.xx) max. length _____ 71 m
 Luffing jib (No. 1309.xx) max. length _____ 66.8 m
 Max. combination _____ main boom 38 m and luffing jib 66.8 m
 Fixed jib (No. 0806.xx) _____ 32 m
 Auxiliary jib _____ 30 t

Remarks

1. The lifting capacities stated are valid for lifting operation only (corresponding with crane classification according to F.E.M. 1.001. crane group A1).
2. Crane standing on firm, horizontal ground.
3. The weight of the lifting device (hoisting ropes, hook block, shackle etc.) must be deducted from the gross lifting capacity to obtain a net lifting value.
4. Additional equipment on boom (e.g. boom walkways, auxiliary jib) must be deducted to get the net lifting capacity.
5. For max. wind speed please refer to lift chart in operator's cab or manual.
6. Working radii are measured from center of swing and under load.
7. The lifting capacities are valid for 360 degrees of swing.
8. Calculation of stability under load is based on DIN 15019 / part 2 / chart 1 and ISO 4305 Table 1 + 2, tipping angle 4°.
9. The structures are calculated according to F.E.M. 1.001 - 1998 (EN 13001-1; EN 13001-2).

Transport dimensions and weights

Basic machine and boom (No. 1512.xx)

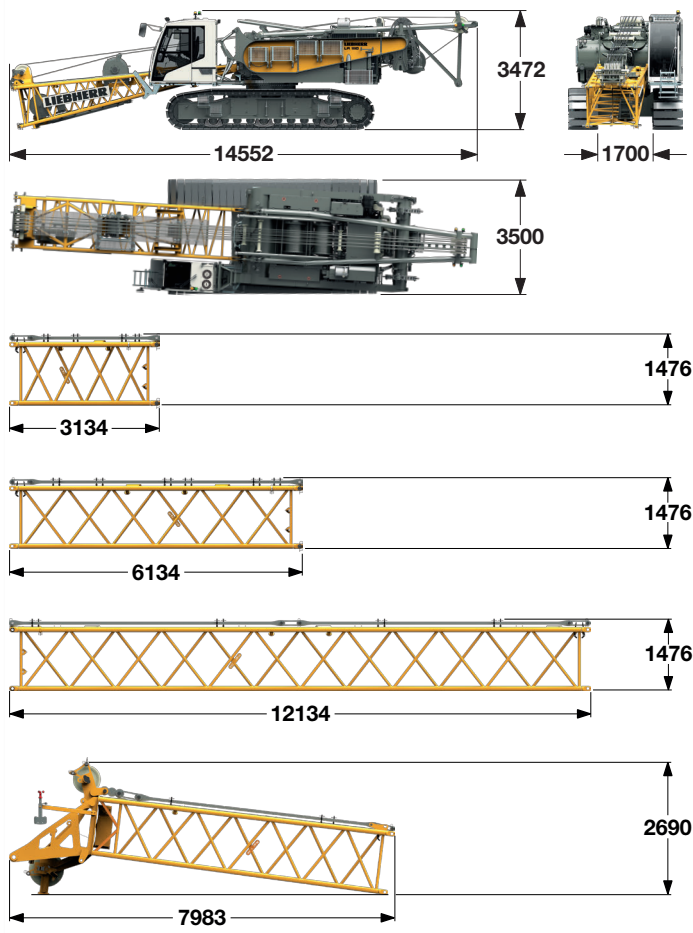

Basic machine

with A-frame, 2x 120 kN crane winches, boom foot and crawlers, without basic counterweight

Width	3500 mm
Weight without hoist rope	57000 kg
Weight of hoist rope	3.42 kg/m

Boom section (No. 1512.22)

3 m

Width	1610 mm
Weight incl. main boom pendants	471 kg
Weight incl. main boom and luffing jib pendants	537 kg

Boom section (No. 1512.22)

6 m

Width	1610 mm
Weight incl. main boom pendants	760 kg
Weight incl. main boom and luffing jib pendants	870 kg

Boom section (No. 1512.22)

12 m

Width	1610 mm
Weight incl. main boom pendants	1392 kg
Weight incl. main boom and luffing jib pendants	1612 kg

Boom head (No. 1512.22)

Width	1819 mm
Weight incl. main boom pendants	2190 kg

Transport options

Basic machine and crawlers

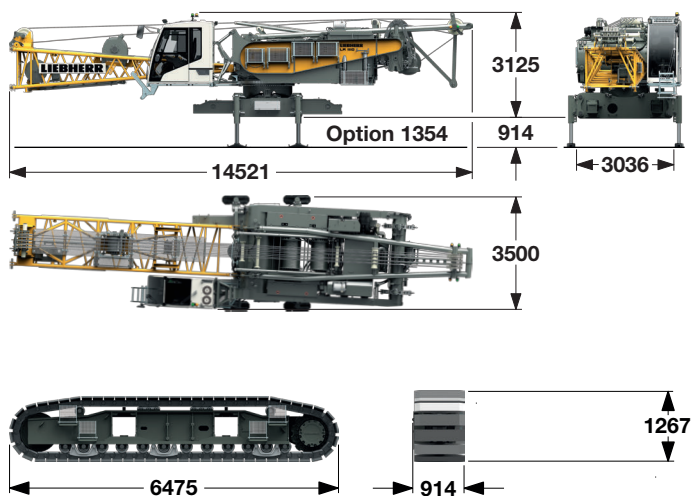

Basic machine

with A-frame, 2x 120 kN crane winches, boom foot, without basic counterweight and crawlers

Width	3500 mm
Weight without hoist rope	37500 kg
Weight of hoist rope	3.42 kg/m

Crawler

2x

Track pads	900 mm
Width	914 mm
Weight	10200 kg

Transport dimensions and weights

Luffing jib (No. 1309.xx)

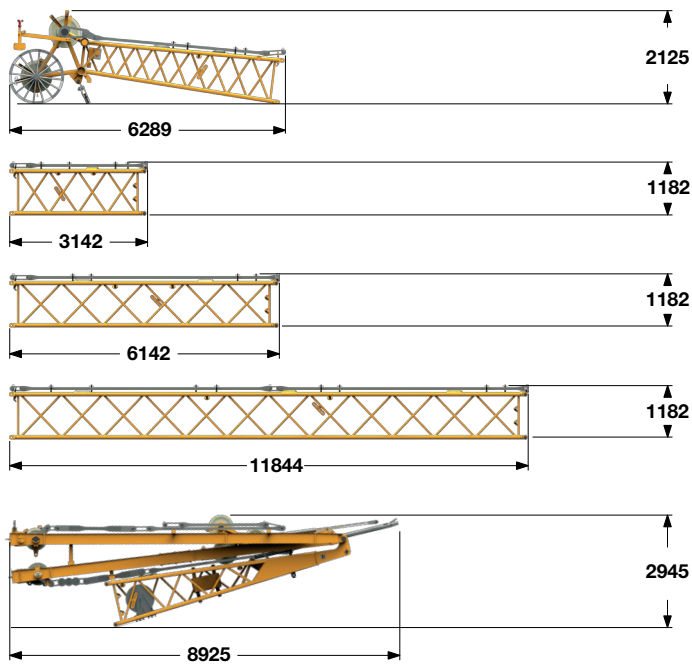

*) Including pendants

Luffing jib head (No. 1309.22)

Width	1392 mm
Weight*	1115 kg

Luffing jib section (No. 1309.20) 3 m

Width	1392 mm
Weight*	302 kg

Luffing jib section (No. 1309.20) 6 m

Width	1392 mm
Weight*	510 kg

Luffing jib section (No. 1309.20) 11.7 m

Width	1390 mm
Weight*	942 kg

Luffing jib foot with A-frames (No. 1309.22)

Width	1624 mm
Weight*	4183 kg

Fixed jib (No. 0806.xx)

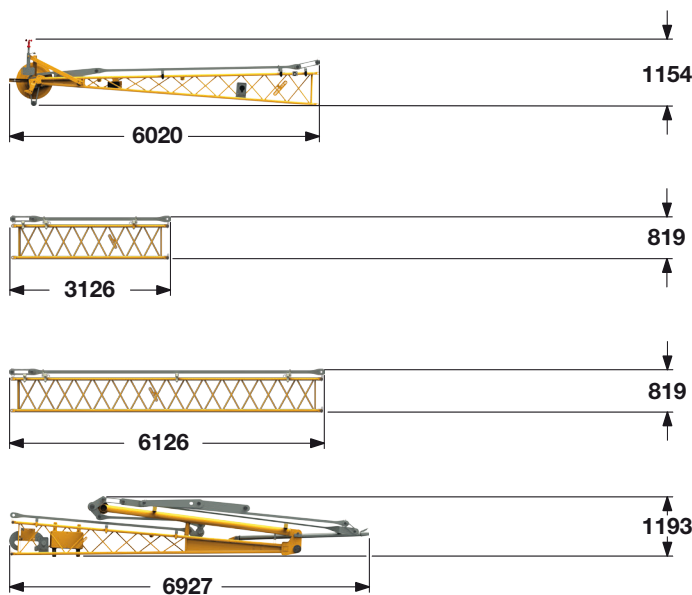

*) Including pendants

Fixed jib head (No. 0806.16)

Width	920 mm
Weight*	424 kg

Fixed jib section (No. 0806.15) 3 m

Width	930 mm
Weight*	145 kg

Fixed jib section (No. 0806.15) 6 m

Width	928 mm
Weight*	250 kg

Fixed jib foot with A-frame (No. 0806.20)

Width	1800 mm
Weight*	1237 kg

Transport dimensions and weights

Counterweight

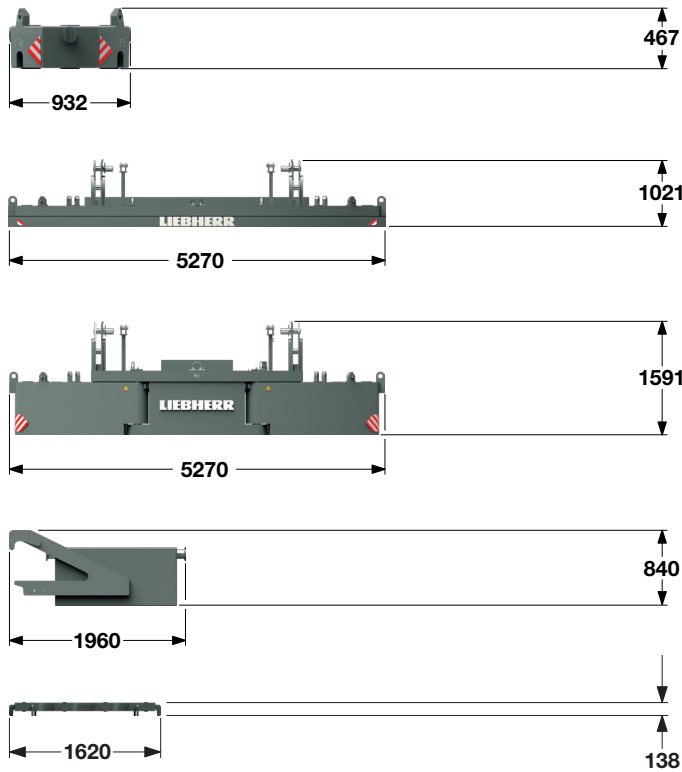

Counterweight	12x
Width	945 mm
Weight	1500 kg

Standard counterweight	1x
Width	1475 mm
Weight	16000 kg

Swinging counterweight option	1x
Width	1475 mm
Weight	16000 kg

Carbody counterweight	2x
	Standard
Width	1640 mm
Weight	7500 kg

Carbody counterweight	2x
	Standard
Width	1530 mm
Weight	1250 kg

Hooks

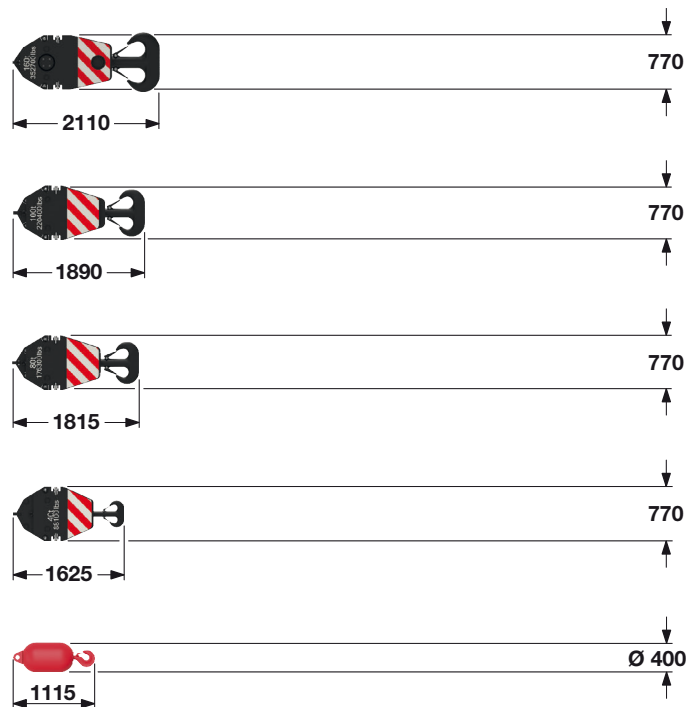

160 t hook block – 7 sheaves	
Width	885 mm
Weight	1500 / 2250 / 3000 kg

100 t hook block – 5 sheaves	
Width	745 mm
Weight	1300 / 1800 / 2300 kg

80 t hook block – 3 sheaves	
Width	565 mm
Weight	1000 / 1500 / 2000 kg

40 t hook block – 1 sheave	
Width	490 mm
Weight	700 / 1100 / 1500 kg

12.5 t single hook	
Width	400 mm
Weight	600 kg

Boom combinations

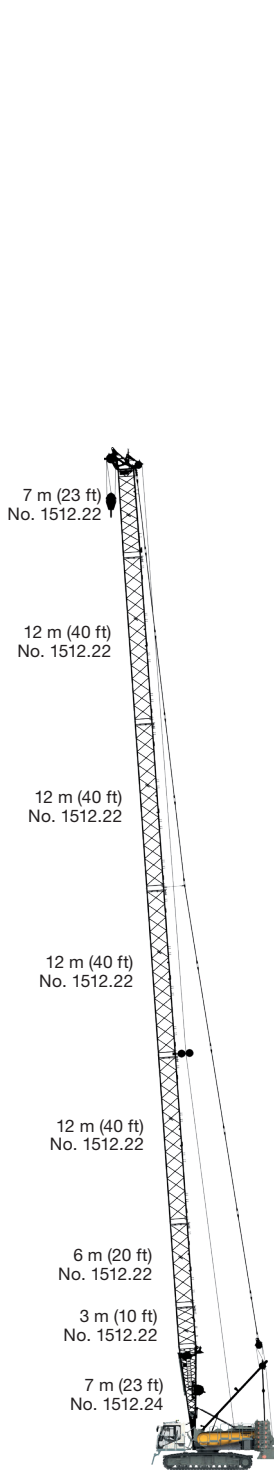

Main boom No. 1512.xx — 71 m

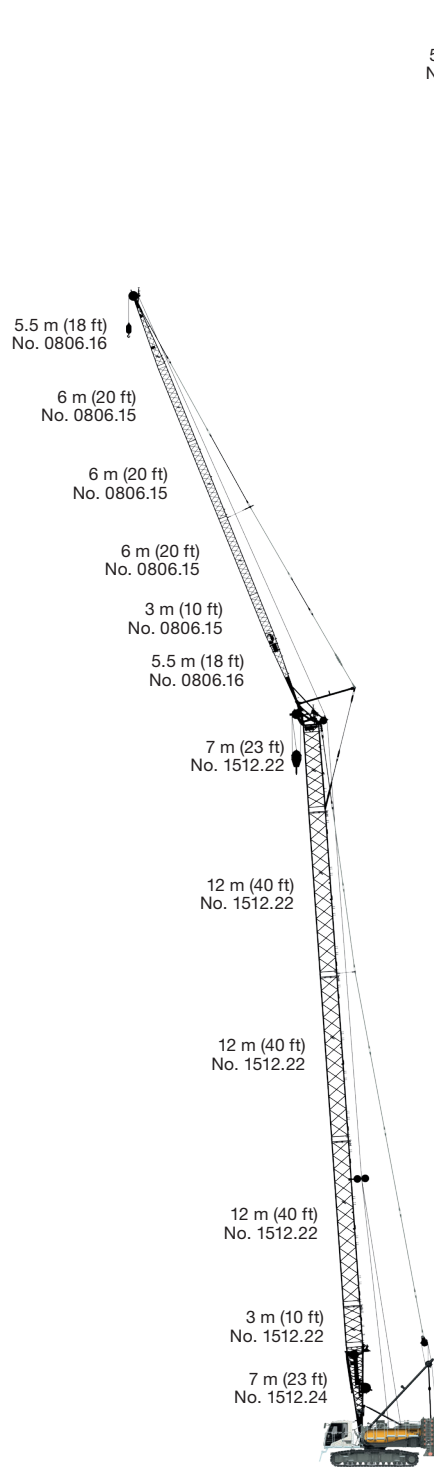

Max. combination — 85 m

Main boom No. 1512.xx — 53 m

Fixed jib No. 0806.xx — 32 m

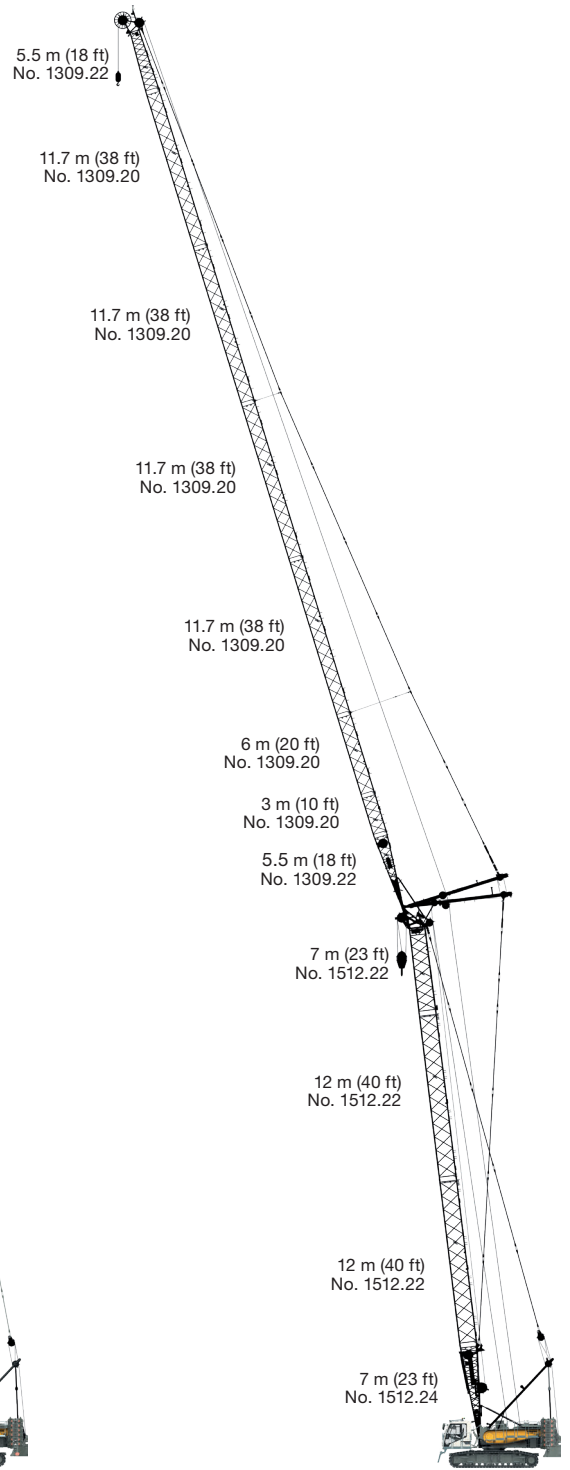

Max. combination — 104.8 m

Main boom No. 1512.xx — 38.0 m

Luffing jib No. 1309.xx — 66.8 m

Max. combination — 98.8 m

Main boom No. 1512.xx — 41.0 m

Luffing jib No. 1309.xx — 57.8 m

Technical description



Engine

Power rating according to ISO 9249, 230 kW (308 hp) at 1700 rpm
Engine type ———— Liebherr D 944 A7 SCR
Fuel tank ———— 850 l capacity with continuous level indicator and reserve warning
Engine complies with NRMM exhaust certification EPA/CARB Tier 4f and 97/68 EC Stage IV.



Hydraulic system

A double axial displacement pump supplies the open loop hydraulic system, allowing all functions to be operated simultaneously. To minimize peak pressure an automatic working pressure cut-off is integrated in the pump. All filters are electronically monitored. The use of synthetic environmentally friendly (biodegradable) oils is possible.
Working pressure ———— max. 350 bar
Oil tank capacity ———— 685 l



Luffing jib winch

Line pull ———— 82 kN
Rope diameter ———— 20 mm
Jib luffing ———— 46 sec. from 15° to 78°



Boom winch

Line pull ———— 116.3 kN
Rope diameter ———— 20 mm
Boom luffing ———— 44 sec. from 15° to 86°



Swing

Consists of rollerbearing with external teeth, swing drive with fixed axial piston hydraulic motor, spring loaded and hydraulically released multi-disc holding brake, planetary gearbox and pinion.
Both swing modes are possible – speed control or free swing.
A multi-disc holding brake acts automatically at zero swing motion.
Swing speed from 0 – 2.1 rpm continuously variable.



Main winches

Line pull (4th layer) ———— 120 kN
Rope diameter ———— 26 mm
Diameter (1st layer) ———— 580 mm
Rope speed ———— 0 – 136 m/min
Rope capacity in 4 layers ———— 256 m
The winches are outstanding in their compact design and easy assembly. Propulsion is via a planetary gearbox in an oil bath.
Load support by the hydraulic system; additional safety factor provided by a spring loaded, multi-disc holding brake.
The main winches use pressure controlled, variable flow hydraulic motors. This system features sensors that automatically adjust oil flow to provide max. winch speed depending on load.

Option – winch with free-fall system:

Clutch and braking functions on the free-fall system are provided by a compact designed, low wear and maintenance-free multi-disc brake.



Control

The heart of the hydraulic crawler cranes is the Liebherr control system which has been developed and manufactured in-house. It includes all control and monitoring functions and is designed to withstand extreme environmental conditions and heavy duty construction tasks. Complete machine operating data as well as warning signals and irregularities are clearly displayed on the high resolution monitor in the operator's cab in the required language.

The electro-hydraulic proportional control allows several movements to be performed simultaneously. This ensures that all categories of loads can be positioned with utmost precision.



Crawlers

Propulsion through axial piston motor, hydraulically released spring loaded multi-disc brake, crawler tracks, hydraulic chain tensioning device.
Track pads ———— 900 mm
Drive speed ———— max. 2.8 km/h



Noise emission

Noise emissions correspond with 2000/14/EC directive.

Guaranteed sound pressure level L_{PA} in the cabin ———— ≤ 71 dB(A)
Guaranteed sound power level L_{WA} ———— ≤ 108 dB(A)
Vibration transmitted to the hand-arm system of the machine operator ———— < 2.5 m/s²
Vibration transmitted to the whole body of the machine operator ———— < 0.5 m/s²

Main boom 86° - 15° (No. 1512.xx)

34 t counterweight and 17.5 t carbody counterweight

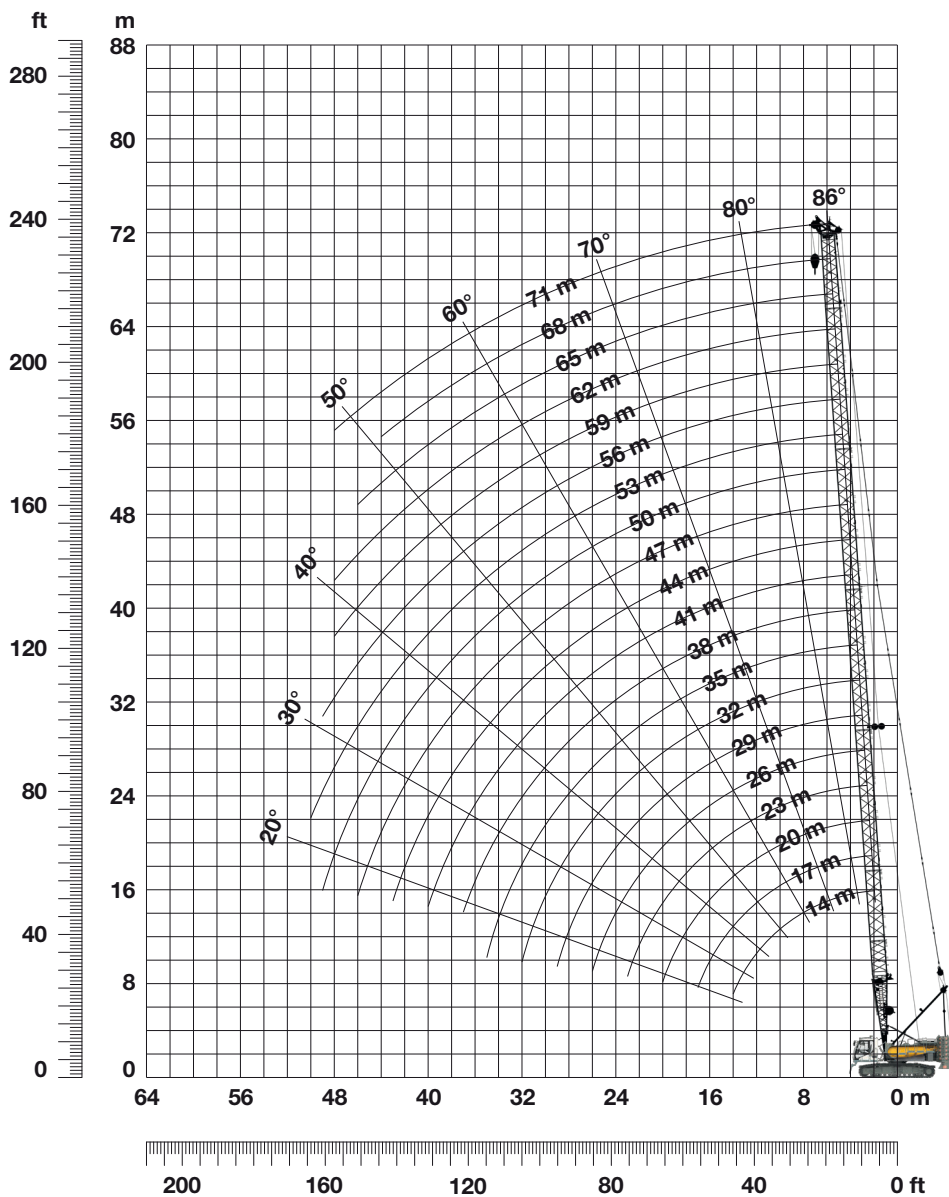

Auxiliary jib 30 t



The maximum capacity of the auxiliary jib is 30 t. The corresponding load chart is programmed in the LMI system.

Main boom configuration (No. 1512.xx)

Configuration for boom lengths between 14 m and 71 m

	Length	Amount of boom extensions																						
		7 m	10 m	13 m	16 m	19 m	22 m	25 m	28 m	31 m	34 m	37 m	40 m	43 m	46 m	49 m	52 m	55 m	58 m	61 m	64 m	67 m	70 m	
Boom foot	7 m	1	1	1	1	1	1	1	1	1	1	1	1	1	1	1	1	1	1	1	1	1	1	
Boom insert	3 m		1		1		1		1		1		1		1		1		1		1		1	
Boom insert	6 m			1	1		1		1		1		1		1		1		1		1		1	
Boom insert	12 m				1	1	1	1	1	1	1	1	1	1	3	3	3	3	3	3	4	4	4	4
Boom head	7 m	1	1	1	1	1	1	1	1	1	1	1	1	1	1	1	1	1	1	1	1	1	1	
Boom length (m)		14	17	20	23	26	29	32	35	38	41	44	47	50	53	56	59	62	65	68	71			
Auxiliary jib applicable		✓	✓	✓	✓	✓	✓	✓	✓	✓	✓	✓	✓	✓	✓	✓	✓	✓	✓	✓	✓	✓	✓	

Lift chart for main boom (No. 1512.xx)

TLT 11943069 - M00000 V7

34 t counterweight and 17.5 t carbody counterweight

Capacities in metric tonnes for boom lengths (14 m - 71 m) – with 120 kN winches

Radius (m)	Boom length in (m)																		Radius (m)		
	14	17	20	23	26	29	32	35	38	41	44	47	50	53	56	59	62	65		68	71
	t	t	t	t	t	t	t	t	t	t	t	t	t	t	t	t	t	t	t	t	t
3	115.5																				3
4	113.1	111.9	96.2	91.7	86.3	82.1															4
5	93.1	88.1	83.6	79.5	75.9	72.4	67.4	60.8	53.5	48.3	41.9										5
6	74.0	70.6	67.6	64.8	62.3	59.9	57.6	55.5	50.5	46.1	40.8	40.6	34.3	30.7	27.2						6
7	61.2	58.8	56.6	54.6	52.7	50.9	49.2	47.5	46.0	43.8	39.0	39.3	33.2	30.0	26.8	24.4	21.8	19.3	17.6	16.2	7
8	50.6	50.3	48.6	47.0	45.6	44.1	42.8	41.5	40.3	39.1	36.8	36.9	32.3	29.2	25.9	23.6	21.2	18.9	17.4	16.1	8
9	42.8	42.8	42.5	41.2	40.1	38.9	37.8	36.7	35.7	34.7	33.8	32.8	31.3	28.3	25.2	23.0	20.7	18.4	16.9	15.6	9
10	37.0	37.0	36.9	36.6	35.7	34.7	33.8	32.8	32.0	31.1	30.3	29.5	28.8	27.5	24.4	22.2	20.2	18.0	16.6	15.1	10
12	28.9	28.9	28.9	28.8	28.7	28.4	27.7	27.0	26.3	25.7	25.1	24.4	23.9	23.3	22.7	21.0	19.3	17.1	15.7	14.3	12
14	23.5	23.5	23.5	23.4	23.4	23.3	23.2	22.7	22.2	21.7	21.2	20.7	20.2	19.7	19.0	18.4	17.6	16.5	15.0	13.6	14
16		19.6	19.6	19.6	19.5	19.4	19.3	19.2	19.1	18.6	18.2	17.7	17.1	16.6	16.0	15.5	14.8	14.2	13.6	13.0	16
20			14.5	14.5	14.4	14.3	14.2	14.1	14.0	13.9	13.7	13.3	12.8	12.3	11.9	11.5	10.9	10.4	9.9	9.4	20
22				12.7	12.7	12.5	12.5	12.3	12.3	12.1	12.0	11.7	11.3	10.9	10.5	10.0	9.5	9.1	8.6	8.1	22
26					10.0	9.9	9.8	9.7	9.6	9.5	9.4	9.2	8.9	8.5	8.2	7.8	7.4	7.0	6.5	6.1	26
28						8.9	8.8	8.7	8.6	8.5	8.3	8.2	8.0	7.6	7.3	6.9	6.5	6.1	5.8	5.3	28
32							7.1	7.0	6.9	6.8	6.7	6.5	6.5	6.2	5.9	5.5	5.2	4.8	4.5	4.1	32
34								6.3	6.3	6.1	6.0	5.9	5.8	5.6	5.3	5.0	4.6	4.3	3.9	3.6	34
38									5.1	5.0	4.9	4.7	4.6	4.5	4.4	4.0	3.7	3.4	3.1	2.7	38
40										4.5	4.4	4.3	4.2	4.0	3.9	3.6	3.3	3.0	2.7	2.4	40
44											3.6	3.4	3.3	3.2	3.1	2.9	2.7	2.4	2.1		44
46												3.1	3.0	2.9	2.7	2.6	2.4	2.1			46
48													2.7	2.5	2.4	2.3	2.2				48
50														2.2	2.1						50

34 t swinging counterweight 90° and 17.5 t carbody counterweight

TLT 11943069 - M00000 V7

Capacities in metric tonnes for boom lengths (17 m - 71 m) - with 120 kN winches

Radius (m)	Boom length in (m)																		Radius (m)		
	17	20	23	26	29	32	35	38	41	44	47	50	53	56	59	62	65	68		71	
	t	t	t	t	t	t	t	t	t	t	t	t	t	t	t	t	t	t	t	t	t
6.9																				16.2	6.9
7																				16.2	7
8																23.6	21.2	18.9	17.4	16.1	8
9													28.3	25.2	23.0	20.7	18.4	16.9	15.6		9
10										33.4	33.5	30.5	27.5	24.4	22.2	20.2	18.0	16.6	15.1		10
12							30.6	29.9	29.2	28.5	27.8	27.2	26.3	23.2	21.0	19.3	17.1	15.7	14.3		12
14			26.4	26.4	26.3	26.2	25.8	25.3	24.7	24.2	23.6	23.1	22.5	21.3	19.7	18.4	16.5	15.0	13.6		14
16	22.2	22.2	22.1	22.1	22.0	21.9	21.8	21.7	21.3	20.8	20.4	19.8	19.2	18.7	18.1	17.2	15.5	14.2	13.0		16
18		19.0	18.9	18.9	18.8	18.7	18.6	18.5	18.4	18.1	17.6	17.0	16.5	16.0	15.5	14.9	14.3	13.3	12.3		18
20		16.5	16.4	16.4	16.3	16.2	16.1	16.0	15.9	15.8	15.4	14.9	14.4	14.0	13.5	12.9	12.4	12.0	11.4		20
22			14.4	14.5	14.3	14.3	14.1	14.0	13.9	13.8	13.6	13.1	12.7	12.3	11.8	11.4	10.9	10.5	10.0		22
26				11.5	11.4	11.3	11.2	11.1	11.0	10.9	10.7	10.5	10.1	9.8	9.4	8.9	8.5	8.1	7.7		26
28					10.2	10.0	10.0	9.8	9.7	9.6	9.5	9.1	8.8	8.4	8.0	7.6	7.2	6.8	6.8		28
32						8.3	8.2	8.1	8.0	7.9	7.7	7.6	7.5	7.2	6.8	6.5	6.1	5.8	5.4		32
34							7.4	7.4	7.2	7.1	7.0	6.9	6.8	6.5	6.2	5.8	5.5	5.2	4.8		34
38								6.1	6.0	5.9	5.7	5.6	5.5	5.4	5.1	4.8	4.5	4.2	3.8		38
40									5.4	5.3	5.2	5.1	5.0	4.8	4.7	4.4	4.1	3.7	3.4		40
44										4.4	4.3	4.2	4.1	3.9	3.8	3.6	3.3	3.0	2.7		44
46											3.9	3.8	3.7	3.5	3.4	3.3	3.0	2.7	2.4		46
48												3.4	3.3	3.2	3.0	2.9	2.7	2.4	2.1		48
50													3.0	2.8	2.7	2.6	2.5	2.2			50
55														2.1							55

Above lift chart is for reference only.

For actual lift duty and complete chart with all available configurations please refer to lift chart in operator's cab or manual.

Working range - luffing jib 78° - 15° (No. 1309.xx)

Main boom 88° - 45°

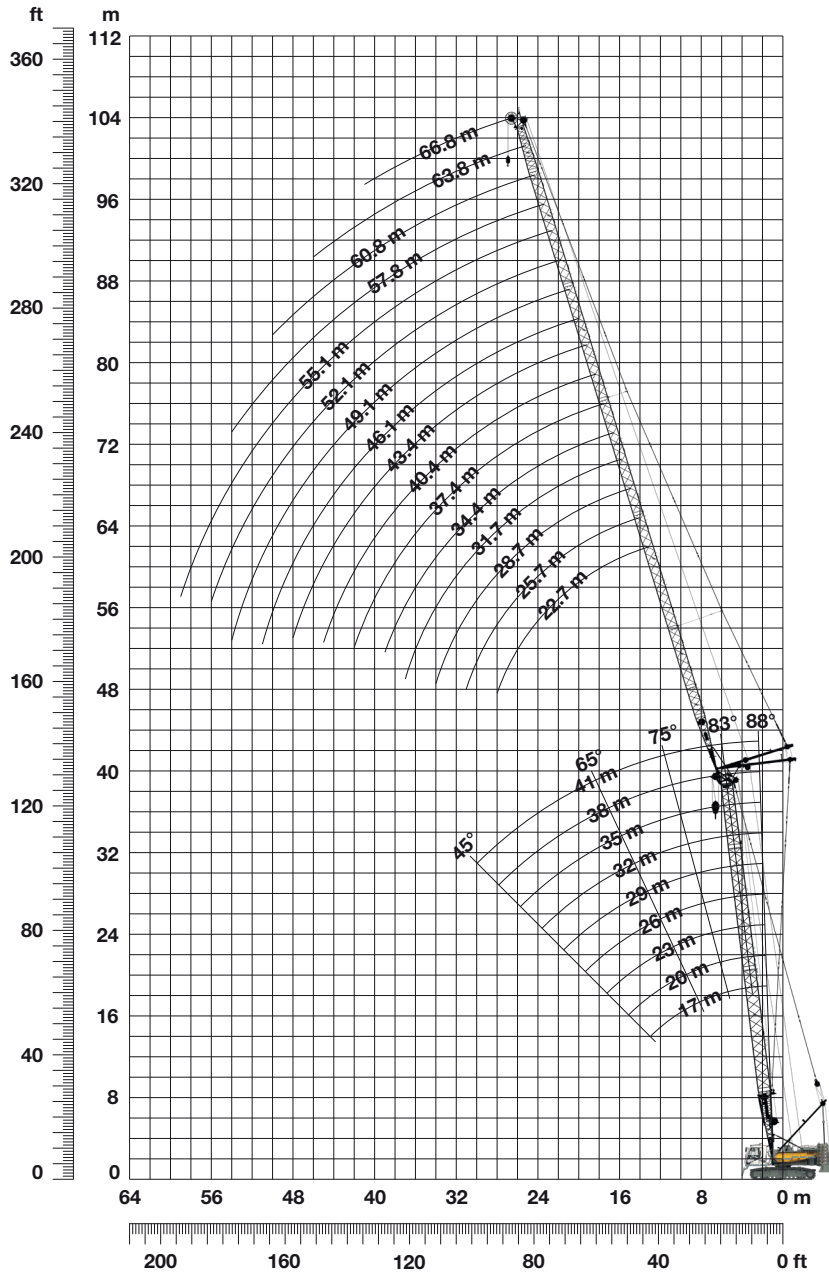

Boom configuration for main boom lengths (17 m – 41 m) – see table on page 10

Jib configuration for jib lengths (22.7 m – 66.8 m)

	Length	Amount of luffing jib extensions															
Luffing jib foot	5.5 m	1	1	1	1	1	1	1	1	1	1	1	1	1	1	1	1
Luffing jib insert	3 m		1		1		1		1		1		1		1		1
Luffing jib insert	6 m			1	1		1		1		1		1		1		1
Luffing jib insert	11.7 m	1	1	1	1	2	2	2	2	3	3	3	3	4	4	4	4
Luffing jib head	5.5 m	1	1	1	1	1	1	1	1	1	1	1	1	1	1	1	1
Luffing jib length (m)		22.7	25.7	28.7	31.7	34.4	37.4	40.4	43.4	46.1	49.1	52.1	55.1	57.8	60.8	63.8	66.8

Lift chart - luffing jib (No. 1309.xx)

TLT 11943069 - M00000 V7

Main boom angle 88°, standard counterweight

Main boom 17 m

Radius (m)	Jib length in (m)							
	22.7 t	31.7 t	37.4 t	43.4 t	49.1 t	55.1 t	60.8 t	66.8 t
7.7	34.8							
10	27.4	24.5						
11	25.1	22.4	20.3					
12	22.7	20.8	19.2	15.7				
14	19.5	18.0	16.7	14.9	12.7			
15	18.0	16.6	15.6	14.4	12.3	9.7		
16	16.7	15.5	14.7	13.4	12.1	9.4	8.1	
17	15.7	14.6	13.8	12.7	11.5	9.2	7.9	6.3
20	13.0	12.1	11.5	10.7	10.0	8.5	7.4	5.9
24	10.6	9.9	9.4	8.8	8.2	7.4	6.7	5.4
32		7.3	6.9	6.5	6.0	5.5	5.0	4.3
38			5.7	5.3	4.9	4.5	4.0	3.5
44				4.4	4.0	3.6	3.3	2.8
50					3.4	3.0	2.6	2.2
55						2.5	2.2	

Main boom 23 m

Radius (m)	Jib length in (m)							
	22.7 t	31.7 t	37.4 t	43.4 t	49.1 t	55.1 t	60.8 t	66.8 t
7.9	29.2							
10	24.4	21.0						
11	22.5	19.6	17.5					
13	19.1	17.2	15.8	14.1				
14	17.9	16.2	14.8	13.2	11.7			
15	16.6	15.1	13.9	12.6	11.2	9.0		
16	15.4	14.1	13.2	11.9	10.7	8.8	7.4	
18	13.7	12.7	11.7	10.7	9.6	8.4	7.2	5.8
24	10.0	9.2	8.7	8.0	7.3	6.6	5.8	4.9
32		6.8	6.4	5.9	5.4	4.9	4.4	3.8
38			5.3	4.8	4.4	4.0	3.6	3.1
44				4.1	3.7	3.2	2.9	2.5
48					3.3	2.8	2.5	2.1
50					3.1	2.7	2.3	
55						2.3		

Main boom 29 m

Radius (m)	Jib length in (m)							
	22.7 t	31.7 t	37.4 t	43.4 t	49.1 t	55.1 t	60.8 t	66.8 t
8.1	25.9							
10	22.8	19.0						
12	19.7	17.2	15.3					
13	18.3	16.0	14.4	12.8				
14	17.2	15.1	13.7	12.2	10.5			
15	16.0	14.3	12.9	11.6	10.2	8.2		
16	15.0	13.4	12.3	11.0	9.7	8.2	6.8	
18	13.4	12.0	11.0	10.0	8.9	7.8	6.6	5.3
24	9.9	8.9	8.3	7.6	6.8	6.1	5.3	4.5
32		6.7	6.2	5.7	5.2	4.6	4.1	3.4
38			5.2	4.7	4.3	3.8	3.3	2.8
44				4.0	3.5	3.1	2.7	2.3
46					3.4	2.9	2.5	2.1
50					3.0	2.5	2.2	
55						2.2		

Main boom 35 m

Radius (m)	Jib length in (m)							
	22.7 t	31.7 t	37.4 t	43.4 t	49.1 t	55.1 t	60.8 t	66.8 t
8.3	21.8							
11	19.0	15.5						
12	18.1	14.7	12.9					
13	17.0	14.1	12.3	10.5				
14	16.3	13.5	11.9	10.2	8.7			
16	14.5	12.3	10.9	9.4	8.2	6.9		
17	13.7	11.8	10.5	9.0	7.9	6.6	5.6	
18	13.1	11.4	10.0	8.7	7.6	6.4	5.4	4.4
24	9.8	8.7	7.9	7.0	6.2	5.3	4.4	3.6
34		5.6	5.7	5.2	4.7	4.0	3.5	2.8
38			5.1	4.6	4.1	3.6	3.1	2.5
44				3.9	3.5	3.0	2.6	2.1
46					3.3	2.8	2.4	2.0
50					3.0	2.5	2.1	
55						2.2		

Main boom 38 m

Radius (m)	Jib length in (m)							
	22.7 t	31.7 t	37.4 t	43.4 t	49.1 t	55.1 t	60.8 t	66.8 t
8.4	18.7							
11	16.3	13.4						
12	15.5	12.7	11.2					
13	14.7	12.1	10.7	9.1				
14	14.0	11.6	10.3	8.8	7.5			
16	12.6	10.5	9.3	8.1	7.0	6.0		
17	11.9	10.0	9.0	7.8	6.8	5.7	4.8	
18	11.4	9.6	8.6	7.5	6.5	5.5	4.7	3.7
20	10.5	8.8	7.8	6.9	6.0	5.1	4.3	3.5
24	9.1	7.5	6.7	5.9	5.2	4.4	3.7	3.0
34		5.1	5.2	4.5	3.9	3.2	2.7	2.1
38			4.7	4.1	3.5	2.9	2.4	
42				3.7	3.2	2.6	2.1	
44				3.6	3.1	2.5		
50					2.7	2.2		

Main boom 41 m

Radius (m)	Jib length in (m)					
	22.7 t	31.7 t	37.4 t	43.4 t	49.1 t	55.1 t
8.5	16.8					
11	14.9	12.1				
12	14.2	11.5	10.1			
13	13.4	11.0	9.6	8.2		
14	12.7	10.5	9.3	7.9	6.7	
16	11.5	9.6	8.4	7.3	6.3	5.3
18	10.6	8.8	7.7	6.7	5.8	4.9
20	9.7	8.0	7.1	6.2	5.3	4.5
24	8.5	6.9	6.1	5.2	4.6	3.8
28		6.2	5.4	4.6	4.0	3.4
34		5.4	4.8	4.0	3.4	2.8
38			4.4	3.7	3.1	2.5
44				3.2	2.7	2.1
46					2.6	2.0
50					2.4	

Capacities in metric tonnes with luffing jib (No. 1309.xx) 34 t counterweight + 17.5 t carbody counterweight. Above lift chart is for reference only. For actual lift duty and complete chart with all available configurations please refer to lift chart in operator's cab or manual.

Lift chart - luffing jib (No. 1309.xx)

TLT 11943069 - M00000 V7

Main boom angle 83°, standard counterweight

Main boom 17 m

Radius (m)	Jib length in (m)							
	22.7	31.7	37.4	43.4	49.1	55.1	60.8	66.8
t	t	t	t	t	t	t	t	t
11.1	28.6							
14	22.2	20.5						
16	19.1	17.8	17.0					
18	16.6	15.5	14.8	13.7				
19	15.6	14.6	13.9	13.0	11.4			
22	12.9	12.2	11.7	11.0	10.2	8.3		
24	11.8	11.0	10.5	9.9	9.3	8.0	6.9	5.4
26	10.7	10.0	9.6	9.1	8.6	7.6	6.7	5.3
30		8.5	8.2	7.8	7.3	6.8	6.0	5.0
34		7.4	7.1	6.7	6.4	5.8	5.4	4.7
40			5.8	5.5	5.2	4.8	4.4	3.9
46				4.6	4.3	3.8	3.5	3.2
50					3.8	3.4	3.1	2.7
55						2.9	2.6	2.2
60							2.1	

Main boom 23 m

Radius (m)	Jib length in (m)							
	22.7	31.7	37.4	43.4	49.1	55.1	60.8	66.8
t	t	t	t	t	t	t	t	t
11.9	24.6							
15	19.4	17.8						
17	16.9	15.7	14.6					
18	15.8	14.6	13.8	12.3				
20	14.0	13.1	12.3	11.3	10.2			
22	12.4	11.6	11.0	10.3	9.4	7.9		
24	11.2	10.5	10.0	9.3	8.6	7.5	6.5	
26	10.3	9.6	9.1	8.6	7.9	7.1	6.2	5.0
30		8.1	7.8	7.3	6.8	6.2	5.5	4.8
34		7.2	6.7	6.4	5.9	5.4	4.9	4.2
38			6.0	5.5	5.2	4.7	4.2	3.7
40			5.6	5.1	4.8	4.4	4.0	3.5
46				4.3	4.0	3.6	3.3	2.8
50					3.5	3.1	2.8	2.4
55						2.7	2.4	

Main boom 29 m

Radius (m)	Jib length in (m)							
	22.7	31.7	37.4	43.4	49.1	55.1	60.8	66.8
t	t	t	t	t	t	t	t	t
12.6	22.7							
16	18.1	16.2						
17	17.0	15.2	13.7					
19	14.9	13.6	12.6	11.2				
22	12.6	11.6	10.7	9.9	8.9			
24	11.3	10.5	9.9	9.0	8.2	7.1	6.0	
26	10.5	9.6	9.0	8.3	7.5	6.7	5.8	4.7
30		8.2	7.8	7.2	6.6	5.9	5.3	4.4
34		7.3	6.7	6.3	5.8	5.2	4.7	4.0
36		6.8	6.3	5.9	5.5	4.8	4.4	3.8
40			5.6	5.1	4.8	4.3	3.8	3.3
42			4.7	4.9	4.4	4.0	3.6	3.1
46				4.4	3.9	3.5	3.2	2.7
50					3.5	3.1	2.8	2.3
55						2.7	2.4	

Main boom 35 m

Radius (m)	Jib length in (m)							
	22.7	31.7	37.4	43.4	49.1	55.1	60.8	66.8
t	t	t	t	t	t	t	t	t
13.3	18.6							
16	16.6	13.6						
18	15.2	12.7	11.1					
20	13.9	11.7	10.4	8.9				
22	12.6	10.9	9.6	8.4	7.2			
24	11.4	10.1	9.0	7.9	6.8	5.7		
26	10.6	9.5	8.5	7.5	6.5	5.5	4.6	
28	9.9	8.8	8.1	7.1	6.2	5.3	4.4	3.6
32		7.7	7.2	6.5	5.7	4.9	4.1	3.4
36		6.9	6.3	5.8	5.2	4.5	3.9	3.1
42			5.4	4.9	4.4	3.9	3.4	2.7
48				4.2	3.8	3.3	2.9	2.4
50					3.6	3.1	2.7	2.2
55						2.7	2.4	
60							2.0	

Main boom 38 m

Radius (m)	Jib length in (m)							
	22.7	31.7	37.4	43.4	49.1	55.1	60.8	66.8
t	t	t	t	t	t	t	t	t
13.7	15.6							
17	13.5	11.3						
18	12.9	10.8	9.4					
20	11.7	9.9	8.8	7.6				
22	10.9	9.2	8.1	7.1	6.2			
24	10.1	8.5	7.5	6.6	5.8	4.9		
26	9.6	7.9	7.1	6.2	5.4	4.6	3.9	
28	9.1	7.5	6.7	5.9	5.2	4.4	3.7	3.0
32		6.9	6.1	5.3	4.7	4.0	3.3	2.7
36		6.3	5.6	4.9	4.2	3.6	3.0	2.4
40			5.1	4.5	3.9	3.2	2.7	2.1
42			4.9	4.3	3.7	3.1	2.5	
48				3.8	3.3	2.7	2.2	
50					3.1	2.6	2.0	
55						2.3		

Main boom 41 m

Radius (m)	Jib length in (m)					
	22.7	31.7	37.4	43.4	49.1	55.1
t	t	t	t	t	t	t
14.1	13.7					
17	12.0	9.9				
19	11.0	9.2	8.1			
22	9.8	8.1	7.2	6.2	5.3	
24	9.2	7.5	6.6	5.8	5.0	4.1
26	8.7	7.1	6.2	5.4	4.7	3.9
28	8.3	6.7	5.9	5.2	4.4	3.7
32		6.2	5.4	4.6	4.0	3.3
36		5.7	5.0	4.3	3.6	3.0
40			4.6	3.9	3.3	2.7
42			4.4	3.8	3.2	2.6
44				3.6	3.1	2.5
46				3.5	3.0	2.3
48				3.3	2.8	2.2
50					2.7	2.1

Capacities in metric tonnes with luffing jib (No. 1309.xx) 34 t counterweight + 17.5 t carbody counterweight. Above lift chart is for reference only. For actual lift duty and complete chart with all available configurations please refer to lift chart in operator's cab or manual.

Lift chart - luffing jib (No. 1309.xx)

TLT 11943069 - M00000 V7

Main boom angle 75°, standard counterweight

Main boom 17 m

Radius (m)	Jib length in (m)							
	22.7 t	31.7 t	37.4 t	43.4 t	49.1 t	55.1 t	60.8 t	66.8 t
16.4	19.0							
22	13.5	13.1						
24	12.1	11.8	11.5					
26	10.9	10.7	10.5	10.0				
28	9.9	9.7	9.5	9.1	8.7			
32		8.1	7.9	7.7	7.4	6.9		
34		7.5	7.3	7.1	6.9	6.4	6.0	
36		6.9	6.7	6.5	6.3	5.9	5.5	4.7
40			5.8	5.6	5.4	5.1	4.7	4.3
42			5.4	5.2	5.0	4.8	4.4	3.9
46				4.5	4.3	4.1	3.8	3.4
48				4.1	4.0	3.8	3.5	3.1
50					3.7	3.5	3.3	2.9
55						2.9	2.7	2.5
60						2.4	2.2	2.0

Main boom 23 m

Radius (m)	Jib length in (m)							
	22.7 t	31.7 t	37.4 t	43.4 t	49.1 t	55.1 t	60.8 t	66.8 t
18	16.0							
22	13.0	12.1						
26	10.5	10.1	9.6					
28	9.6	9.3	8.9	8.4				
30	8.7	8.5	8.2	7.7	7.3			
32		7.7	7.6	7.2	6.8	6.2		
36		6.6	6.4	6.2	5.8	5.3	4.9	
38		6.1	5.9	5.7	5.4	4.9	4.5	4.0
40			5.5	5.3	5.0	4.6	4.2	3.7
42			5.1	4.9	4.7	4.3	3.9	3.4
44			4.7	4.5	4.4	4.0	3.6	3.1
48				3.9	3.8	3.5	3.1	2.7
50				3.6	3.5	3.2	2.9	2.5
55					2.9	2.7	2.4	2.0
60						2.2		

Main boom 29 m

Radius (m)	Jib length in (m)							
	22.7 t	31.7 t	37.4 t	43.4 t	49.1 t	55.1 t	60.8 t	66.8 t
19.5	13.5							
24	10.9	10.1						
26	10.0	9.2	8.8					
30	8.3	7.9	7.5	7.0				
32		7.3	6.9	6.4	5.9			
34		6.8	6.4	5.9	5.5	5.0		
36		6.2	6.0	5.5	5.1	4.6	4.1	
38		5.8	5.6	5.1	4.7	4.2	3.8	
40		5.3	5.2	4.8	4.4	3.9	3.5	3.0
42			4.8	4.5	4.1	3.6	3.2	2.7
44			4.5	4.2	3.8	3.4	3.0	2.5
46			4.1	3.9	3.6	3.1	2.7	2.3
48				3.7	3.4	2.9	2.5	2.1
50				3.4	3.1	2.7	2.4	
55					2.6	2.3		

Main boom 35 m

Radius (m)	Jib length in (m)							
	22.7 t	31.7 t	37.4 t	43.4 t	49.1 t	55.1 t	60.8 t	66.8 t
21.1	11.4							
26	9.1	8.4						
28	8.4	7.7	7.2					
30	7.8	7.1	6.7	6.1				
32	7.2	6.6	6.1	5.6				
34		6.1	5.7	5.2	4.7			
36		5.7	5.3	4.8	4.3	3.8		
38		5.3	4.9	4.5	4.0	3.5	3.1	
40		5.0	4.6	4.2	3.7	3.2	2.8	2.3
42		4.6	4.3	3.9	3.5	3.0	2.6	2.1
44			4.0	3.7	3.2	2.8	2.3	
46			3.8	3.4	3.0	2.6	2.2	
48				3.2	2.8	2.4		
50				3.0	2.7	2.2		
55					2.2			

Main boom 38 m

Radius (m)	Jib length in (m)						
	22.7 t	31.7 t	37.4 t	43.4 t	49.1 t	55.1 t	60.8 t
21.9	10.4						
24	9.5						
26	8.7	7.9					
28	8.0	7.2					
30	7.4	6.6	6.1				
32	6.9	6.1	5.7	5.1			
34	6.4	5.7	5.2	4.7	4.2		
36		5.3	4.9	4.4	3.9	3.4	
38		5.0	4.6	4.1	3.6	3.1	2.6
40		4.7	4.3	3.8	3.3	2.8	2.4
42		4.4	4.0	3.5	3.1	2.6	2.2
44			3.8	3.3	2.9	2.4	
46			3.5	3.1	2.7	2.2	
48			3.3	2.9	2.5	2.1	
50				2.7	2.4		

Main boom 41 m

Radius (m)	Jib length in (m)					
	22.7 t	31.7 t	37.4 t	43.4 t	49.1 t	55.1 t
22.6	9.2					
24	9.0					
26	8.2					
28	7.6	6.7				
30	7.0	6.2	5.7			
32	6.5	5.7	5.2	4.7		
34	6.0	5.3	4.8	4.3	3.8	
36		5.0	4.5	4.0	3.5	
38		4.6	4.2	3.7	3.2	2.7
40		4.4	3.9	3.4	3.0	2.5
42		4.1	3.7	3.2	2.8	2.3
44			3.5	3.0	2.6	2.1
46			3.3	2.8	2.4	
48			3.0	2.6	2.2	
50				2.5	2.1	

Capacities in metric tonnes with luffing jib (No. 1309.xx) 34 t counterweight + 17.5 t carbody counterweight. Above lift chart is for reference only. For actual lift duty and complete chart with all available configurations please refer to lift chart in operator's cab or manual.

Lift chart - luffing jib (No. 1309.xx)

TLT 11943069 - M00000 V7

Main boom angle 65°, standard counterweight

Main boom 17 m

Radius (m)	Jib length in (m)							
	22.7 t	31.7 t	37.4 t	43.4 t	49.1 t	55.1 t	60.8 t	66.8 t
22.6	12.1							
28	9.2	8.9						
30	8.4	8.1						
32		7.5	7.3					
34		6.9	6.7					
36		6.3	6.1	5.9				
38		5.8	5.7	5.5	5.2			
40		5.4	5.3	5.0	4.8			
42			4.9	4.7	4.5	4.2		
44			4.5	4.3	4.1	3.9		
46				4.0	3.8	3.6	3.2	
48				3.7	3.5	3.3	3.0	2.6
50				3.5	3.3	3.1	2.8	2.4
55					2.7	2.5	2.3	
60						2.0		

Main boom 23 m

Radius (m)	Jib length in (m)							
	22.7 t	31.7 t	37.4 t	43.4 t	49.1 t	55.1 t	60.8 t	
25.1	9.9							
32	7.2	6.8						
34	6.6	6.3	6.1					
36		5.8	5.6					
38		5.4	5.2	4.9				
40		4.9	4.8	4.5				
42		4.6	4.4	4.2	3.9			
44			4.1	3.9	3.6	3.2		
46			3.8	3.6	3.3	2.9		
48			3.5	3.3	3.1	2.7	2.3	
50				3.1	2.9	2.5	2.2	
55					2.3	2.1		

Main boom 29 m

Radius (m)	Jib length in (m)							
	22.7 t	31.7 t	37.4 t	43.4 t	49.1 t			
27.6	8.0							
34	6.0	5.6						
36	5.6	5.2						
38		4.8	4.5					
40		4.4	4.2	3.7				
44		3.8	3.6	3.2	2.8			
46			3.3	3.0	2.6			
48			3.1	2.8	2.4			
50			2.9	2.6	2.3			
55				2.1				

Main boom 35 m

Radius (m)	Jib length in (m)							
	22.7 t	31.7 t	37.4 t	43.4 t				
30.2	6.1							
36	4.9	4.3						
38	4.6	4.0						
40		3.7	3.3					
44		3.2	2.9	2.4				
46		3.0	2.6	2.3				
48			2.4	2.1				
50			2.3					
0								
0								

Main boom 38 m

Radius (m)	Jib length in (m)						
	22.7 t	31.7 t	37.4 t				
31.4	5.3						
38	4.2	3.5					
40	3.9	3.3	2.8				
42		3.1	2.6				
44		2.8	2.5				
46		2.6	2.3				
48		2.4	2.1				

Main boom 41 m

Radius (m)	Jib length in (m)						
	22.7 t	31.7 t	37.4 t				
32.7	4.6						
38	3.7	3.0					
40	3.5	2.8					
42		2.6	2.2				
44		2.4	2.0				
46		2.2					
48		2.1					

Capacities in metric tonnes with luffing jib (No. 1309.xx) 34 t counterweight + 17.5 t carbody counterweight. Above lift chart is for reference only. For actual lift duty and complete chart with all available configurations please refer to lift chart in operator's cab or manual.

Lift chart - luffing jib (No. 1309.xx)

TLT 11943069 - M00000 V7

Main boom angle 45°, standard counterweight

Main boom 17 m

Radius (m)	Jib length in (m)							
	22.7 t	31.7 t	37.4 t	43.4 t				
32.8	6.5							
36	5.7							
42		4.2						
44		3.9						
46			3.4					
48			3.2					
50			2.9	2.7				
55				2.2				

Main boom 23 m

Radius (m)	Jib length in (m)						
	22.7 t	31.7 t	37.4 t				
37	4.6						
38	4.4						
40	4.1						
46		2.9					
48		2.7					
50			2.3				

Main boom 41 m

Radius (m)	Jib length in (m)							
	22.7 t							
41.3	3.1							
42	3.0							
44	2.8							

Main boom 32 m

Radius (m)	Jib length in (m)							
	22.7 t							
43.4	2.4							
44	2.4							
46	2.2							

Capacities in metric tonnes with luffing jib (No. 1309.xx) 34 t counterweight + 17.5 t carbody counterweight. Above lift chart is for reference only. For actual lift duty and complete chart with all available configurations please refer to lift chart in operator's cab or manual.

Working range - luffing jib 78° - 15° (No. 1309.xx)

Main boom angle 88° - 45°, swinging counterweight 90°

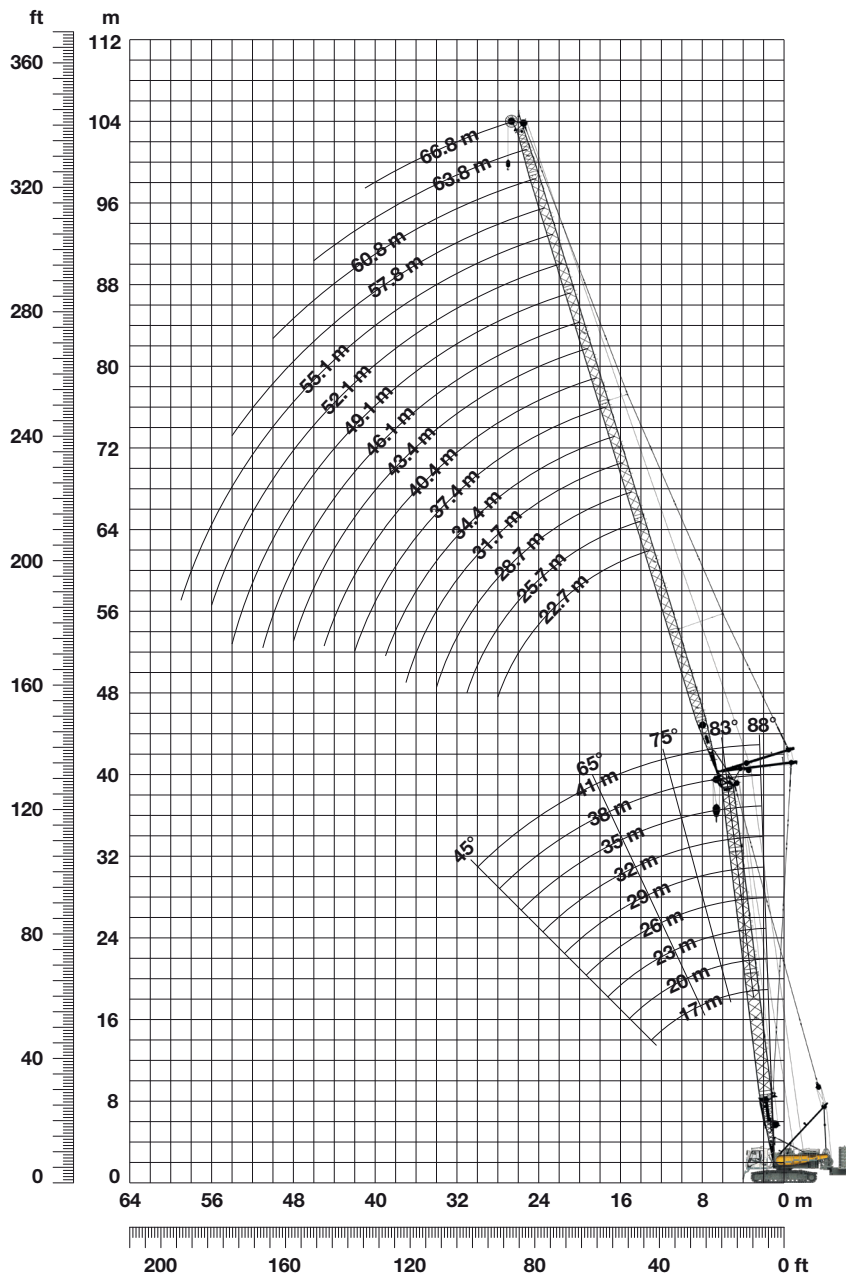

Boom configuration for main boom lengths (17 m - 41 m) - see table on page 10

Jib configuration for jib lengths (22.7 m - 66.8 m)

	Length	Amount of luffing jib extensions															
Luffing jib foot	5.5 m	1	1	1	1	1	1	1	1	1	1	1	1	1	1	1	1
Luffing jib insert	3 m		1		1			1				1			1		1
Luffing jib insert	6 m			1	1			1				1			1		1
Luffing jib insert	11.7 m	1	1	1	1	2	2	2	2	3	3	3	3	4	4	4	4
Luffing jib head	5.5 m	1	1	1	1	1	1	1	1	1	1	1	1	1	1	1	1
Luffing jib length (m)		22.7	25.7	28.7	31.7	34.4	37.4	40.4	43.4	46.1	49.1	52.1	55.1	57.8	60.8	63.8	66.8

Lift chart - luffing jib (No. 1309.xx)

TLT 11943069 - M00000 V7

Main boom angle 88°, swinging counterweight 90°

Main boom 17 m

Radius (m)	Jib length in (m)							
	22.7 t	31.7 t	37.4 t	43.4 t	49.1 t	55.1 t	60.8 t	66.8 t
13				15.4				
14				14.9	12.7			
15			15.6	14.4	12.3	9.7		
16		15.5	14.7	13.4	12.1	9.4	8.1	
17		14.6	13.8	12.7	11.5	9.2	7.9	6.3
19	13.8	12.9	12.2	11.4	10.4	8.7	7.5	6.0
22	11.7	10.8	10.4	9.6	9.0	8.1	6.9	5.6
24	10.6	9.9	9.4	8.8	8.2	7.4	6.7	5.4
28		8.3	8.0	7.5	7.0	6.4	5.7	4.9
32		7.3	6.9	6.5	6.0	5.5	5.0	4.3
38			5.7	5.3	4.9	4.5	4.0	3.5
44				4.4	4.0	3.6	3.3	2.8
50					3.4	3.0	2.6	2.2
55						2.5	2.2	

Main boom 23 m

Radius (m)	Jib length in (m)							
	22.7 t	31.7 t	37.4 t	43.4 t	49.1 t	55.1 t	60.8 t	66.8 t
12.2				14.4				
13				15.8	14.1			
14			14.8	13.2	11.7			
15		15.1	13.9	12.6	11.2	9.0		
16		14.1	13.2	11.9	10.7	8.8	7.4	
18	13.7	12.7	11.7	10.7	9.6	8.4	7.2	5.8
20	12.1	11.2	10.5	9.6	8.8	7.6	6.8	5.5
24	10.0	9.2	8.7	8.0	7.3	6.6	5.8	4.9
28		7.7	7.4	6.8	6.3	5.6	5.0	4.3
32		6.8	6.4	5.9	5.4	4.9	4.4	3.8
38			5.3	4.8	4.4	4.0	3.6	3.1
44				4.1	3.7	3.2	2.9	2.5
48					3.3	2.8	2.5	2.1
50					3.1	2.7	2.3	
55						2.3		

Main boom 29 m

Radius (m)	Jib length in (m)							
	22.7 t	31.7 t	37.4 t	43.4 t	49.1 t	55.1 t	60.8 t	66.8 t
11.2			15.6					
13		16.0	14.4	12.8				
14		15.1	13.7	12.2	10.5			
15		14.3	12.9	11.6	10.2	8.2		
16	15.0	13.4	12.3	11.0	9.7	8.2	6.8	
18	13.4	12.0	11.0	10.0	8.9	7.8	6.6	5.3
20	11.9	10.8	10.0	9.0	8.1	7.1	6.3	5.1
24	9.9	8.9	8.3	7.6	6.8	6.1	5.3	4.5
28		7.6	7.1	6.5	5.9	5.2	4.6	4.0
32		6.7	6.2	5.7	5.2	4.6	4.1	3.4
38			5.2	4.7	4.3	3.8	3.3	2.8
44				4.0	3.5	3.1	2.7	2.3
46					3.4	2.9	2.5	2.1
50					3.0	2.5	2.2	
55						2.2		

Main boom 35 m

Radius (m)	Jib length in (m)							
	22.7 t	31.7 t	37.4 t	43.4 t	49.1 t	55.1 t	60.8 t	66.8 t
11		15.5						
12		14.7	12.9					
13		14.1	12.3	10.5				
14	16.3	13.5	11.9	10.2	8.7			
16	14.5	12.3	10.9	9.4	8.2	6.9		
17	13.7	11.8	10.5	9.0	7.9	6.6	5.6	
18	13.1	11.4	10.0	8.7	7.6	6.4	5.4	4.4
20	11.7	10.3	9.2	8.1	7.1	6.0	5.1	4.1
24	9.8	8.7	7.9	7.0	6.2	5.3	4.4	3.6
34		5.6	5.7	5.2	4.7	4.0	3.5	2.8
38			5.1	4.6	4.1	3.6	3.1	2.5
44				3.9	3.5	3.0	2.6	2.1
46					3.3	2.8	2.4	2.0
50					3.0	2.5	2.1	
55						2.2		

Main boom 38 m

Radius (m)	Jib length in (m)							
	22.7 t	31.7 t	37.4 t	43.4 t	49.1 t	55.1 t	60.8 t	66.8 t
10.3		13.6						
12		12.7	11.2					
13	14.1	12.1	10.7	9.1				
14	14.0	11.6	10.3	8.8	7.5			
16	12.6	10.5	9.3	8.1	7.0	6.0		
17	11.9	10.0	9.0	7.8	6.8	5.7	4.8	
18	11.4	9.6	8.6	7.5	6.5	5.5	4.7	3.7
20	10.5	8.8	7.8	6.9	6.0	5.1	4.3	3.5
24	9.1	7.5	6.7	5.9	5.2	4.4	3.7	3.0
32		6.1	5.4	4.7	4.1	3.4	2.9	2.2
34		5.1	5.2	4.5	3.9	3.2	2.7	2.1
38			4.7	4.1	3.5	2.9	2.4	
42				3.7	3.2	2.6	2.1	
44				3.6	3.1	2.5		
50					2.7	2.2		

Main boom 41 m

Radius (m)	Jib length in (m)					
	22.7 t	31.7 t	37.4 t	43.4 t	49.1 t	55.1 t
10.4		12.2				
12	14.2	11.5	10.1			
13	13.4	11.0	9.6	8.2		
14	12.7	10.5	9.3	7.9	6.7	
16	11.5	9.6	8.4	7.3	6.3	5.3
18	10.6	8.8	7.7	6.7	5.8	4.9
20	9.7	8.0	7.1	6.2	5.3	4.5
24	8.5	6.9	6.1	5.2	4.6	3.8
28		6.2	5.4	4.6	4.0	3.4
34		5.4	4.8	4.0	3.4	2.8
38			4.4	3.7	3.1	2.5
42				3.4	2.8	2.3
44				3.2	2.7	2.1
46					2.6	2.0
50					2.4	

Capacities in metric tonnes with luffing jib (No. 1309.xx) 34 t counterweight + 17.5 t carbody counterweight. Above lift chart is for reference only. For actual lift duty and complete chart with all available configurations please refer to lift chart in operator's cab or manual.

Lift chart - luffing jib (No. 1309.xx)

TLT 11943069 - M00000 V7

Main boom angle 83°, swinging counterweight 90°

Main boom 17 m

Radius (m)	Jib length in (m)							
	22.7	31.7	37.4	43.4	49.1	55.1	60.8	66.8
13.8	t	20.5						
14	22.2	20.5						
16	19.1	17.8	17.0					
18	16.6	15.5	14.8	13.7				
19	15.6	14.6	13.9	13.0	11.4			
22	12.9	12.2	11.7	11.0	10.2	8.3		
24	11.8	11.0	10.5	9.9	9.3	8.0	6.9	5.4
26	10.7	10.0	9.6	9.1	8.6	7.6	6.7	5.3
30		8.5	8.2	7.8	7.3	6.8	6.0	5.0
34		7.4	7.1	6.7	6.4	5.8	5.4	4.7
40			5.8	5.5	5.2	4.8	4.4	3.9
46				4.6	4.3	3.8	3.5	3.2
50					3.8	3.4	3.1	2.7
55						2.9	2.6	2.2
60							2.1	

Main boom 23 m

Radius (m)	Jib length in (m)							
	22.7	31.7	37.4	43.4	49.1	55.1	60.8	66.8
11.9	24.6							
15	19.4	17.8						
17	16.9	15.7	14.6					
18	15.8	14.6	13.8	12.3				
20	14.0	13.1	12.3	11.3	10.2			
22	12.4	11.6	11.0	10.3	9.4	7.9		
24	11.2	10.5	10.0	9.3	8.6	7.5	6.5	
26	10.3	9.6	9.1	8.6	7.9	7.1	6.2	5.0
30		8.1	7.8	7.3	6.8	6.2	5.5	4.8
34		7.2	6.7	6.4	5.9	5.4	4.9	4.2
38			6.0	5.5	5.2	4.7	4.2	3.7
40			5.6	5.1	4.8	4.4	4.0	3.5
46				4.3	4.0	3.6	3.3	2.8
50					3.5	3.1	2.8	2.4
55						2.7	2.4	

Main boom 29 m

Radius (m)	Jib length in (m)							
	22.7	31.7	37.4	43.4	49.1	55.1	60.8	66.8
12.6	22.7							
16	18.1	16.2						
17	17.0	15.2	13.7					
19	14.9	13.6	12.6	11.2				
22	12.6	11.6	10.7	9.9	8.9			
24	11.3	10.5	9.9	9.0	8.2	7.1	6.0	
26	10.5	9.6	9.0	8.3	7.5	6.7	5.8	4.7
30		8.2	7.8	7.2	6.6	5.9	5.3	4.4
34		7.3	6.7	6.3	5.8	5.2	4.7	4.0
36		6.8	6.3	5.9	5.5	4.8	4.4	3.8
40			5.6	5.1	4.8	4.3	3.8	3.3
42			4.7	4.9	4.4	4.0	3.6	3.1
46				4.4	3.9	3.5	3.2	2.7
50					3.5	3.1	2.8	2.3
55						2.7	2.4	

Main boom 35 m

Radius (m)	Jib length in (m)							
	22.7	31.7	37.4	43.4	49.1	55.1	60.8	66.8
13.3	18.6							
16	16.6	13.6						
18	15.2	12.7	11.1					
20	13.9	11.7	10.4	8.9				
22	12.6	10.9	9.6	8.4	7.2			
24	11.4	10.1	9.0	7.9	6.8	5.7		
26	10.6	9.5	8.5	7.5	6.5	5.5	4.6	
28	9.9	8.8	8.1	7.1	6.2	5.3	4.4	3.6
32		7.7	7.2	6.5	5.7	4.9	4.1	3.4
36		6.9	6.3	5.8	5.2	4.5	3.9	3.1
42			5.4	4.9	4.4	3.9	3.4	2.7
48				4.2	3.8	3.3	2.9	2.4
50					3.6	3.1	2.7	2.2
55						2.7	2.4	
60							2.0	

Main boom 38 m

Radius (m)	Jib length in (m)							
	22.7	31.7	37.4	43.4	49.1	55.1	60.8	66.8
13.7	15.6							
17	13.5	11.3						
18	12.9	10.8	9.4					
20	11.7	9.9	8.8	7.6				
22	10.9	9.2	8.1	7.1	6.2			
24	10.1	8.5	7.5	6.6	5.8	4.9		
26	9.6	7.9	7.1	6.2	5.4	4.6	3.9	
28	9.1	7.5	6.7	5.9	5.2	4.4	3.7	3.0
32		6.9	6.1	5.3	4.7	4.0	3.3	2.7
36		6.3	5.6	4.9	4.2	3.6	3.0	2.4
40			5.1	4.5	3.9	3.2	2.7	2.1
42			4.9	4.3	3.7	3.1	2.5	
48				3.8	3.3	2.7	2.2	
50					3.1	2.6	2.0	
55						2.3		

Main boom 41 m

Radius (m)	Jib length in (m)					
	22.7	31.7	37.4	43.4	49.1	55.1
14.1	13.7					
17	12.0	9.9				
19	11.0	9.2	8.1			
22	9.8	8.1	7.2	6.2	5.3	
24	9.2	7.5	6.6	5.8	5.0	4.1
26	8.7	7.1	6.2	5.4	4.7	3.9
28	8.3	6.7	5.9	5.2	4.4	3.7
32		6.2	5.4	4.6	4.0	3.3
36		5.7	5.0	4.3	3.6	3.0
40			4.6	3.9	3.3	2.7
42			4.4	3.8	3.2	2.6
44				3.6	3.1	2.5
46				3.5	3.0	2.3
48				3.3	2.8	2.2
50					2.7	2.1

Capacities in metric tonnes with luffing jib (No. 1309.xx) 34 t counterweight + 17.5 t carbody counterweight. Above lift chart is for reference only. For actual lift duty and complete chart with all available configurations please refer to lift chart in operator's cab or manual.

Lift chart - luffing jib (No. 1309.xx)

TLT 11943069 - M00000 V7

Main boom angle 75°, swinging counterweight 90°

Main boom 17 m

Radius (m)	Jib length in (m)							
	22.7	31.7	37.4	43.4	49.1	55.1	60.8	66.8
16.4	21.6							
22	15.3	14.5						
24	13.7	13.0	12.5					
26	12.4	11.7	11.4	10.8				
28	11.3	10.8	10.3	9.9	9.3			
32		9.1	8.8	8.4	8.1	7.2		
34		8.5	8.2	7.8	7.5	6.9	6.0	
36		7.9	7.6	7.3	6.9	6.5	5.9	4.7
40			6.7	6.3	6.1	5.7	5.3	4.5
42			6.2	5.9	5.6	5.3	4.9	4.4
46				5.3	5.0	4.6	4.4	3.8
48				4.9	4.7	4.3	4.1	3.6
50					4.4	4.1	3.8	3.4
60						2.6	2.6	2.3
65							2.1	

Main boom 23 m

Radius (m)	Jib length in (m)							
	22.7	31.7	37.4	43.4	49.1	55.1	60.8	66.8
18	18.4							
22	14.8	14.0						
26	12.0	11.6	11.2					
28	10.9	10.6	10.3	9.7				
30	9.5	9.7	9.5	8.9	8.4			
32		8.9	8.7	8.3	7.8	6.9		
36		7.6	7.4	7.2	6.8	6.3	5.6	
38		7.0	6.9	6.7	6.4	5.9	5.3	4.4
42			6.0	5.8	5.6	5.1	4.7	4.1
44			5.6	5.4	5.2	4.8	4.4	3.9
48				4.7	4.5	4.2	3.9	3.4
50				3.9	4.2	3.9	3.6	3.2
55					3.5	3.3	3.1	2.7
60						2.8	2.6	2.2
65							2.2	

Main boom 29 m

Radius (m)	Jib length in (m)							
	22.7	31.7	37.4	43.4	49.1	55.1	60.8	66.8
19.5	15.7							
24	12.7	11.8						
26	11.6	10.8	10.4					
30	9.6	9.3	8.8	8.3				
32		8.6	8.2	7.7	7.2			
34		7.9	7.6	7.1	6.7	6.1		
36		7.3	7.1	6.6	6.2	5.7	5.2	
40		6.3	6.1	5.8	5.4	4.9	4.5	4.0
42			5.7	5.5	5.1	4.6	4.2	3.7
44			5.3	5.1	4.7	4.3	3.9	3.4
46			4.9	4.7	4.5	4.0	3.6	3.2
48				4.4	4.2	3.8	3.4	2.9
50				4.1	3.9	3.6	3.2	2.7
55					3.3	3.1	2.7	2.3
60						2.6	2.3	

Main boom 35 m

Radius (m)	Jib length in (m)							
	22.7	31.7	37.4	43.4	49.1	55.1	60.8	66.8
21.1	13.3							
26	10.7	9.9						
28	9.9	9.2	8.7					
30	9.2	8.5	8.0	7.3				
32	8.4	7.9	7.4	6.9				
34		7.3	6.9	6.4	5.9			
36		6.9	6.4	5.9	5.5	4.9		
38		6.4	6.0	5.5	5.1	4.6	3.9	
40		6.0	5.7	5.2	4.7	4.2	3.8	3.0
42		5.5	5.3	4.9	4.4	3.9	3.5	3.0
46			4.7	4.3	3.9	3.5	3.0	2.5
48				4.1	3.7	3.2	2.8	2.3
50				3.8	3.5	3.0	2.6	2.2
55					3.0	2.6	2.2	
60						2.2		

Main boom 38 m

Radius (m)	Jib length in (m)							
	22.7	31.7	37.4	43.4	49.1	55.1	60.8	66.8
21.9	11.6							
26	10.3	8.7						
30	8.8	8.0	7.1					
32	8.2	7.4	6.9	5.9				
34	7.5	6.9	6.4	5.7	4.9			
36		6.5	6.0	5.5	4.7	3.9		
38		6.1	5.6	5.1	4.6	3.8	3.1	
40		5.7	5.3	4.8	4.3	3.7	3.0	
42		5.4	5.0	4.5	4.0	3.6	2.9	2.2
44			4.7	4.2	3.8	3.3	2.9	2.2
46			4.4	4.0	3.6	3.1	2.7	2.1
48			4.2	3.8	3.3	2.9	2.5	
50				3.6	3.2	2.7	2.3	
55					2.8	2.3		
60						2.0		

Main boom 41 m

Radius (m)	Jib length in (m)					
	22.7	31.7	37.4	43.4	49.1	55.1
22.6	9.2					
28	8.5	7.0				
30	8.1	6.7	5.9			
32	7.8	6.4	5.7	4.8		
34	7.3	6.2	5.4	4.7	3.9	
36		5.9	5.2	4.5	3.8	
38		5.7	5.0	4.3	3.7	3.0
40		5.4	4.8	4.1	3.5	2.9
42		5.1	4.6	4.0	3.4	2.8
44			4.4	3.8	3.3	2.6
46			4.2	3.6	3.1	2.5
48			3.9	3.5	3.0	2.4
50				3.3	2.8	2.3
55					2.5	
60					2.1	

Capacities in metric tonnes with luffing jib (No. 1309.xx) 34 t counterweight + 17.5 t carbody counterweight. Above lift chart is for reference only. For actual lift duty and complete chart with all available configurations please refer to lift chart in operator's cab or manual.

Lift chart - luffing jib (No. 1309.xx)

TLT 11943069 - M00000 V7

Main boom angle 65°, swinging counterweight 90°

Main boom 17 m

Radius (m)	Jib length in (m)							
	22.7	31.7	37.4	43.4	49.1	55.1	60.8	66.8
	t	t	t	t	t	t	t	t
22.6	13.9							
28	10.6							
30	9.7	10.3						
32		8.6	8.4					
36		7.4	7.2	7.0				
38		6.8	6.7	6.4	6.2			
40		6.3	6.2	6.0	5.8			
42			5.8	5.6	5.4	5.1		
44			5.4	5.2	5.0	4.7		
46				4.8	4.6	4.4	4.1	
48				4.5	4.3	4.1	3.8	3.4
50				4.2	4.0	3.8	3.6	3.2
55					3.4	3.2	3.0	2.7
60						2.6	2.5	2.2
65							2.0	

Main boom 23 m

Radius (m)	Jib length in (m)							
	22.7	31.7	37.4	43.4	49.1	55.1	60.8	66.8
	t	t	t	t	t	t	t	t
25.1	11.4							
32	8.4	8.0						
34	7.7	7.4	7.2					
36		6.8	6.6					
38		6.3	6.1	5.9				
40		5.9	5.7	5.5				
42		5.5	5.3	5.1	4.8			
44			4.9	4.7	4.5	4.1		
46			4.6	4.4	4.2	3.8		
48			4.3	4.1	3.9	3.6	3.2	
50				3.8	3.6	3.4	3.0	
55					3.0	2.8	2.5	2.1
60						2.3	2.1	
0								
0								

Main boom 29 m

Radius (m)	Jib length in (m)						
	22.7	31.7	37.4	43.4	49.1	55.1	60.8
	t	t	t	t	t	t	t
27.6	9.4						
34	7.2	6.8					
36	6.6	6.3					
38		5.8	5.6				
40		5.4	5.2	4.8			
42		5.0	4.8	4.4			
44		4.7	4.5	4.2	3.7		
46			4.2	3.9	3.5		
48			3.9	3.6	3.3	2.8	
50			3.6	3.4	3.1	2.6	2.2
55				2.8	2.6	2.2	
60					2.1		

Main boom 35 m

Radius (m)	Jib length in (m)				
	22.7	31.7	37.4	43.4	49.1
	t	t	t	t	t
30.2	7.5				
36	6.0	5.5			
38	5.6	5.1			
40		4.8	4.4		
42		4.5	4.1		
44		4.1	3.8	3.4	
46		3.8	3.6	3.1	2.7
48			3.3	2.9	2.5
50			3.1	2.8	2.4
55				2.3	

Main boom 38 m

Radius (m)	Jib length in (m)				
	22.7	31.7	37.4	43.4	49.1
	t	t	t	t	t
31.4	6.7				
38	5.3	4.6			
40	4.9	4.3	3.9		
44		3.8	3.4	2.9	
46		3.6	3.2	2.7	
48		3.3	3.0	2.5	2.1
50			2.8	2.4	
55				2.0	

Main boom 41 m

Radius (m)	Jib length in (m)			
	22.7	31.7	37.4	43.4
	t	t	t	t
32.7	5.8			
38	4.9	4.1		
40	4.5	3.8		
42		3.6	3.2	
46		3.2	2.8	2.3
48		3.0	2.6	2.1
50		2.8	2.4	
55			2.0	

Capacities in metric tonnes with luffing jib (No. 1309.xx) 34 t counterweight + 17.5 t carbody counterweight. Above lift chart is for reference only. For actual lift duty and complete chart with all available configurations please refer to lift chart in operator's cab or manual.

Lift chart - luffing jib (No. 1309.xx)

TLT 11943069 - M00000 V7

Main boom angle 45°, swinging counterweight 90°

Main boom 17 m

Radius (m)	Jib length in (m)							
	22.7 t	31.7 t	37.4 t	43.4 t	49.1 t			
32.8	7.6							
36	6.7							
42		5.1						
44		4.7						
46			4.2					
50			3.7	3.4				
55				2.9	2.7			
60					2.2			

Main boom 23 m

Radius (m)	Jib length in (m)							
	22.7 t	31.7 t	37.4 t	43.4 t				
37	5.6							
40	5.0							
46		3.7						
48		3.5						
50			3.0					
55				2.3				
0								
0								

Main boom 29 m

Radius (m)	Jib length in (m)						
	22.7 t	31.7 t					
41.3	4.0						
42	3.9						
44	3.6						
50		2.5					

Main boom 32 m

Radius (m)	Jib length in (m)							
	22.7 t							
43.4	3.3							
44	3.2							
46	3.0							
0								

Capacities in metric tonnes with luffing jib (No. 1309.xx) 34 t counterweight + 17.5 t carbody counterweight. Above lift chart is for reference only. For actual lift duty and complete chart with all available configurations please refer to lift chart in operator's cab or manual.

Working range - fixed jib 15° and 30°

(No. 0806.xx)

Main boom 88° – 45°

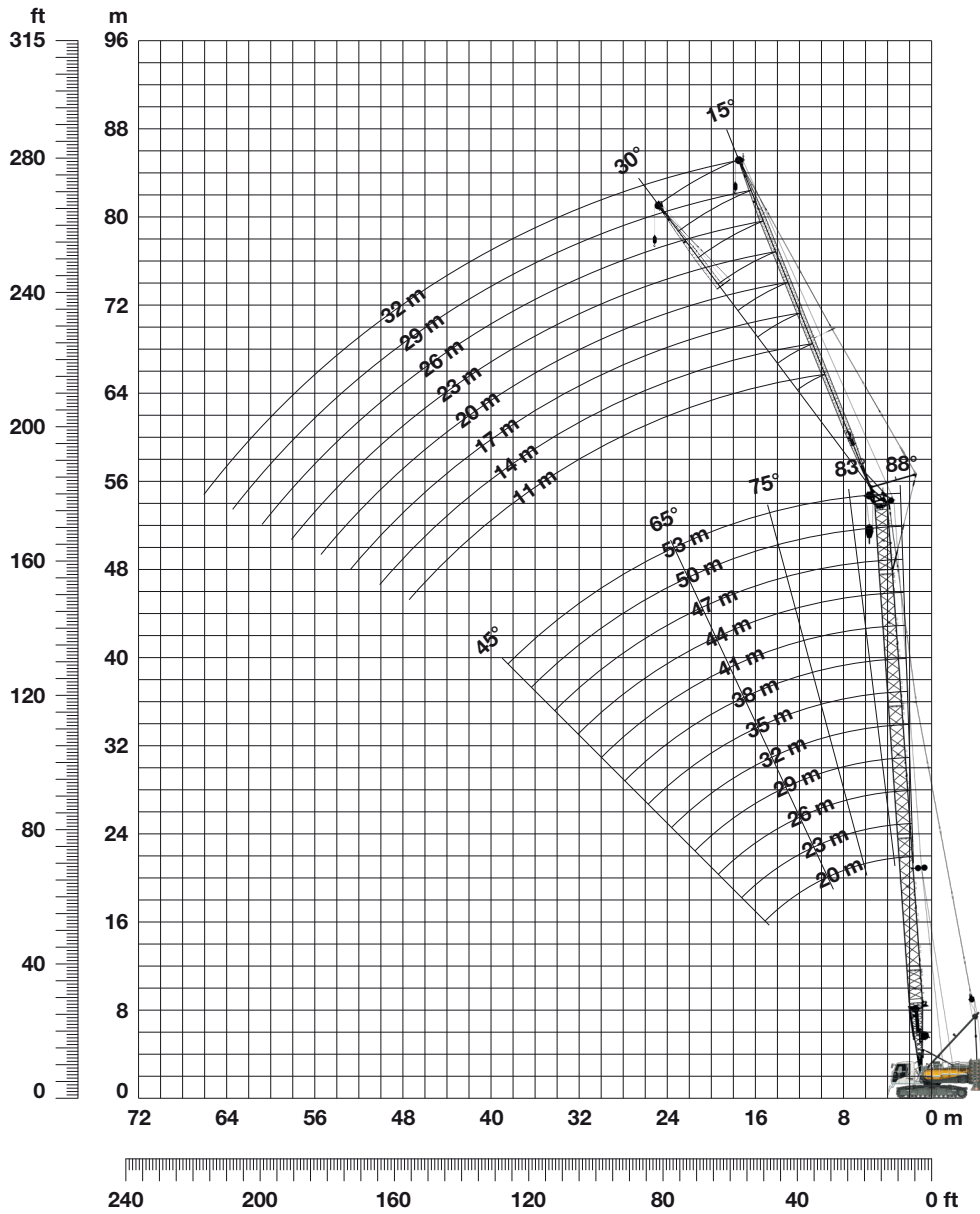

Boom configuration for boom lengths (20 m – 59 m) – see table 1 on page 10

Fixed jib configuration for fixed jib lengths (11 m – 32 m)

	Length	Amount of fixed jib extensions							
		11	14	17	20	23	26	29	32
Fixed jib foot	5.5 m	1	1	1	1	1	1	1	1
Fixed jib insert	3.0 m		1		1		1		1
Fixed jib insert	6.0 m			1	1	2	2	3	3
Fixed jib head	5.5 m	1	1	1	1	1	1	1	1
Fixed jib length (m)		11	14	17	20	23	26	29	32

Lift chart - fixed jib (No. 0806.xx)

TLT 11943069 - M236250

Offset 15°, standard counterweight

Main boom 20 m

Radius (m)	Fixed jib length in (m)			
	11 t	20 t	26 t	32 t
5.1	22.8			
9	21.1	11.2		
12	20.0	10.4	7.6	
14	19.2	9.9	7.3	5.3
18	17.4	9.1	6.7	4.9
20	15.1	8.8	6.5	4.7
24	11.8	8.2	6.0	4.3
30	8.7	7.6	5.6	3.9
38		6.5	5.1	3.4
40			5.1	3.3
44			5.0	3.2
46				3.2

Main boom 26 m

Radius (m)	Fixed jib length in (m)			
	11 t	20 t	26 t	32 t
5.3	22.2			
9	21.3	11.2		
12	20.4	10.5	7.6	
14	19.8	10.1	7.3	5.3
20	14.9	9.1	6.6	4.7
26	10.4	8.2	6.0	4.3
30	8.4	7.8	5.7	4.0
32	7.6	7.7	5.6	3.9
34	6.9	7.4	5.5	3.8
44		4.8	5.0	3.3
50			4.0	3.2
55				3.1

Main boom 29 m

Radius (m)	Fixed jib length in (m)			
	11 t	20 t	26 t	32 t
5.4	21.5			
9	20.8	10.9		
12	19.9	10.4	7.4	
14	19.4	10.0	7.2	5.2
20	14.7	9.0	6.5	4.7
28	9.2	8.1	5.8	4.1
32	7.5	7.7	5.6	3.9
34	6.8	7.2	5.4	3.8
36	6.2	6.6	5.4	3.6
40		5.6	5.2	3.5
50			3.9	3.1
58				2.9

Main boom 32 m

Radius (m)	Fixed jib length in (m)			
	11 t	20 t	26 t	32 t
5.5	21.1			
10	20.2	10.7		
12	19.8	10.4	7.3	
14	19.3	10.1	7.1	5.1
22	12.8	8.9	6.3	4.5
32	7.3	7.8	5.6	3.9
42		5.0	5.2	3.5
44		4.6	4.8	3.4
46		4.2	4.4	3.3
48		3.8	4.1	3.3
55			3.0	3.1
60				2.6

Main boom 38 m

Radius (m)	Fixed jib length in (m)			
	11 t	20 t	26 t	32 t
5.7	20.6			
10	19.7	10.6		
12	19.3	10.3	7.0	
14	19.0	10.0	6.8	
22	12.5	9.0	6.3	4.5
32	7.1	7.6	5.7	4.0
42	4.3	4.7	4.9	3.6
44	3.9	4.3	4.5	3.5
46		3.9	4.2	3.4
48		3.6	3.8	3.4
55			2.8	3.0
60			2.2	2.4

Main boom 44 m

Radius (m)	Fixed jib length in (m)			
	11 t	20 t	26 t	32 t
5.9	18.4			
10	18.0	9.9		
12	17.7	9.8	6.3	
16	17.2	9.5	6.1	4.4
28	8.5	8.4	5.6	4.0
38	4.9	5.4	5.3	3.7
40	4.5	4.9	5.1	3.6
48	2.9	3.3	3.5	3.3
50	2.6	3.0	3.2	3.3
55		2.3	2.5	2.7
58				2.3
60				2.1

Main boom 50 m

Radius (m)	Fixed jib length in (m)			
	11 t	20 t	26 t	32 t
6.1	17.0			
10	16.6	9.0		
13	16.3	8.9	5.8	
16	16.0	8.8	5.7	4.1
22	11.3	8.5	5.5	3.9
30	7.3	7.6	5.2	3.8
32	6.5	6.9	5.2	3.7
38	4.7	5.2	5.0	3.6
44	3.3	3.8	4.0	3.4
50	2.3	2.7	3.0	3.1
55		2.1	2.3	2.5
58				2.1

Main boom 53 m

Radius (m)	Fixed jib length in (m)			
	11 t	20 t	26 t	32 t
6.2	15.5			
10	15.2	8.2		
13	14.9	8.1	5.4	
16	14.6	8.0	5.3	3.8
22	11.0	7.8	5.1	3.6
30	7.0	7.4	4.9	3.5
38	4.5	5.0	4.7	3.4
46	2.8	3.3	3.5	3.2
48	2.5	2.9	3.2	3.2
50	2.2	2.6	2.8	3.0
55			2.1	2.3
57				2.1

Main boom 59 m

Radius (m)	Fixed jib length in (m)			
	11 t	14 t	17 t	20 t
6.4	13.0			
8	12.9	10.3		
9	12.9	10.3	8.2	
10	12.8	10.2	8.2	6.9
13	12.6	10.1	8.0	6.8
20	11.8	9.8	7.8	6.7
28	7.3	7.5	7.6	6.6
36	4.7	4.8	4.9	5.0
40	3.7	3.8	4.0	4.0
44	2.9	3.0	3.2	3.2
48	2.2	2.3	2.5	2.6
50		2.0	2.2	2.3

Capacities in metric tonnes with fixed jib (No. 0806.xx), 34 t counterweight + 17.5 t carbody counterweight. Above lift chart is for reference only. For actual lift duty and complete chart with all available configurations please refer to lift chart in operator's cab or manual.

Lift chart - fixed jib (No. 0806.xx)

TLT 11943069 - M236250

Offset 30°, standard counterweight

Main boom 20 m

Radius (m)	Fixed jib length in (m)			
	11	20	26	32
7.7	19.4			
14	17.4	8.8		
18	15.9	8.2	6.2	
22	13.5	7.9	5.9	4.2
24	12.0	7.9	5.8	4.1
26	10.8	7.6	5.7	3.9
28	9.7	7.4	5.6	3.8
30	8.7	7.2	5.4	3.7
38		6.4	4.8	3.4
40			4.7	3.3
42			4.6	3.3
50				3.2

Main boom 26 m

Radius (m)	Fixed jib length in (m)			
	11	20	26	32
7.9	19.1			
14	17.8	8.8		
18	16.1	8.3	6.2	
22	13.3	8.0	6.0	4.2
24	11.8	7.9	5.9	4.1
26	10.6	7.9	5.8	4.0
28	9.5	7.7	5.7	3.9
32	7.7	7.3	5.5	3.7
34	7.0	7.1	5.3	3.6
44		4.9	4.7	3.4
50			4.1	3.3
55				3.2

Main boom 29 m

Radius (m)	Fixed jib length in (m)			
	11	20	26	32
8	18.6			
16	16.6	8.5		
20	15.1	8.1	6.1	
24	11.7	7.9	5.8	4.0
26	10.4	7.8	5.7	3.9
28	9.4	7.7	5.6	3.8
32	7.6	7.4	5.5	3.7
34	6.9	7.3	5.4	3.6
36	6.3	6.8	5.3	3.5
38	5.7	6.3	5.2	3.5
46		4.4	4.7	3.3
59				2.9

Main boom 32 m

Radius (m)	Fixed jib length in (m)			
	11	20	26	32
8.1	18.5			
16	16.5	8.5		
20	15.0	8.2	6.0	
24	11.6	7.8	5.8	4.0
28	9.2	7.8	5.7	3.9
32	7.5	7.5	5.5	3.7
36	6.1	6.7	5.3	3.6
38	5.6	6.2	5.2	3.5
40	5.1	5.6	5.2	3.5
46		4.3	4.6	3.3
55			3.1	3.2
60				2.7

Main boom 38 m

Radius (m)	Fixed jib length in (m)			
	11	20	26	32
8.4	17.9			
16	16.3	8.5		
20	14.6	8.2	6.0	
24	11.4	7.9	5.8	4.0
30	8.1	7.7	5.6	3.8
36	5.9	6.5	5.4	3.6
42	4.4	5.0	5.2	3.5
44	4.0	4.5	4.8	3.4
46	3.6	4.1	4.4	3.4
55		2.6	2.9	3.2
60			2.2	2.5
64				2.0

Main boom 44 m

Radius (m)	Fixed jib length in (m)			
	11	20	26	32
8.6	16.8			
16	15.9	8.3		
20	13.9	8.1	5.7	
24	11.0	7.8	5.6	3.9
32	7.0	7.5	5.4	3.7
36	5.7	6.3	5.3	3.6
40	4.6	5.2	5.2	3.5
44	3.7	4.3	4.6	3.4
46	3.3	3.9	4.2	3.4
55		2.4	2.7	3.0
60			2.1	2.3
62				2.1

Main boom 50 m

Radius (m)	Fixed jib length in (m)			
	11	20	26	32
8.8	15.5			
16	14.1	8.1		
20	12.8	8.0	5.4	
24	10.5	7.6	5.3	3.8
26	9.4	7.5	5.3	3.7
28	8.5	7.2	5.3	3.7
30	7.6	6.9	5.3	3.6
34	6.1	6.5	5.1	3.6
40	4.4	5.0	4.8	3.5
55		2.2	2.5	2.8
58			2.1	2.4
60				2.1

Main boom 53 m

Radius (m)	Fixed jib length in (m)			
	11	20	26	32
8.9	14.4			
16	13.5	7.9		
20	12.3	7.8	5.0	
24	10.2	7.4	5.0	3.6
26	9.2	7.3	5.0	3.6
28	8.2	7.1	5.0	3.5
30	7.4	6.8	5.0	3.5
34	5.9	6.3	4.9	3.5
36	5.3	5.9	4.8	3.4
44	3.3	4.0	4.3	3.3
55		2.1	2.4	2.7
60				2.0

Main boom 59 m

Radius (m)	Fixed jib length in (m)			
	11	14	17	20
9.1	12.4			
11	12.4	10.0		
13	12.3	10.0	8.0	
18	11.8	9.9	8.0	6.9
20	11.5	9.7	8.0	6.9
28	7.7	8.0	7.6	6.9
36	4.9	5.2	5.9	5.5
44	3.1	3.3	3.5	3.6
46	2.5	2.9	3.1	3.3
48	2.2	2.6	2.8	2.9
50		2.2	2.4	2.6
53				2.1

Capacities in metric tonnes with fixed jib (No. 0806.xx), 34 t counterweight + 17.5 t carbody counterweight. Above lift chart is for reference only. For actual lift duty and complete chart with all available configurations please refer to lift chart in operator's cab or manual.

Working range - fixed jib 15° and 30° (No. 0806.xx)

Main boom 88° – 45°, swinging counterweight 90°

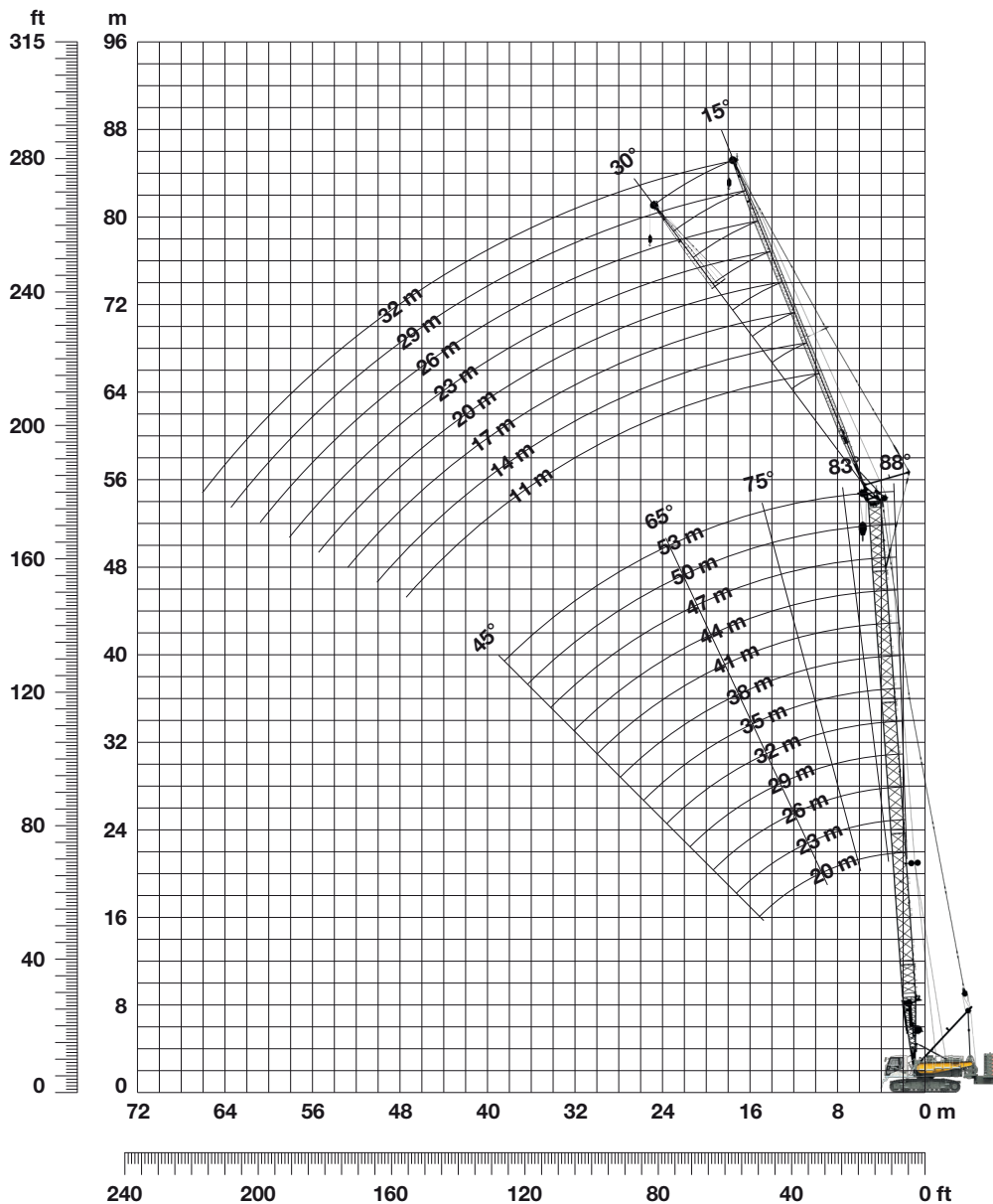

Boom configuration for boom lengths (20 m – 59 m) – see table 1 on page 10

Fixed jib configuration for fixed jib lengths (11 m – 32 m)

	Length	Amount of fixed jib extensions								
		1	1	1	1	1	1	1	1	1
Fixed jib foot	5.5 m	1	1	1	1	1	1	1	1	1
Fixed jib insert	3.0 m		1				1			1
Fixed jib insert	6.0 m			1		1	2	2	3	3
Fixed jib head	5.5 m	1	1	1	1	1	1	1	1	1
Fixed jib length (m)		11	14	17	20	23	26	29	32	

Lift chart - fixed jib (No. 0806.xx)

TLT 11943069 - M236250

Offset 15°, swinging counterweight 90°

Main boom 20 m

Radius (m)	Fixed jib length in (m)			
	11	20	26	32
17	18.0			
20	17.0	8.8		
22	15.1	8.5	6.2	
24	13.5	8.2	6.0	4.3
26	21.5	7.9	5.9	4.2
28	10.9	7.8	5.7	4.0
30	9.9	7.6	5.6	3.9
34		7.4	5.3	3.6
38		7.1	5.1	3.4
42			5.0	3.3
44			5.0	3.2
50				3.1

Main boom 26 m

Radius (m)	Fixed jib length in (m)			
	11	20	26	32
15	19.5			
18	18.3	9.4		
20	16.9	9.1	6.6	
22	14.9	8.8	6.4	4.6
24	13.2	8.5	6.2	4.4
26	11.8	8.2	6.0	4.3
30	9.7	7.8	5.7	4.0
32	8.8	7.7	5.6	3.9
34	8.1	7.6	5.5	3.8
44		5.7	5.1	3.3
50			4.6	3.2
55				3.1

Main boom 29 m

Radius (m)	Fixed jib length in (m)			
	11	20	26	32
14	19.4			
18	18.2	9.3		
20	16.7	9.0	6.5	4.7
22	14.7	8.8	6.3	4.5
24	13.1	8.6	6.1	4.4
26	11.7	8.3	6.0	4.2
30	9.5	7.9	5.7	4.0
32	8.7	7.7	5.6	3.9
34	7.9	7.6	5.4	3.8
44		5.6	5.0	3.3
50			4.6	3.1
55				3.1

Main boom 32 m

Radius (m)	Fixed jib length in (m)			
	11	20	26	32
14	19.3			
18	18.6	9.5	6.7	
20	16.6	9.2	6.5	4.7
22	14.6	8.9	6.3	4.5
26	11.5	8.4	6.0	4.3
32	8.5	7.9	5.6	3.9
38	6.5	6.9	5.3	3.6
42		5.9	5.2	3.5
46		5.0	5.0	3.3
48		4.6	4.8	3.3
55			3.7	3.1
60				3.1

Main boom 38 m

Radius (m)	Fixed jib length in (m)			
	11	20	26	32
14	19.0			
16	18.5	9.8		
20	16.2	9.3	6.4	4.6
24	12.7	8.8	6.2	4.4
30	9.1	8.2	5.8	4.1
36	6.8	7.3	5.5	3.8
42	5.2	5.6	5.2	3.6
44	4.7	5.2	5.1	3.5
46		4.8	5.0	3.4
55			3.5	3.2
60			2.8	3.0
65				2.4

Main boom 44 m

Radius (m)	Fixed jib length in (m)			
	11	20	26	32
12	17.7			
16	17.2	9.5	6.1	
20	15.5	9.1	5.9	4.3
24	12.4	8.7	5.8	4.1
28	9.9	8.4	5.6	4.0
34	7.2	7.5	5.4	3.8
40	5.4	5.9	5.2	3.6
48	3.7	4.1	4.3	3.3
50	3.3	3.8	4.0	3.3
55		3.0	3.2	3.2
60			2.5	2.7
65				2.2

Main boom 50 m

Radius (m)	Fixed jib length in (m)			
	11	20	26	32
12	16.4			
14	16.2	8.8		
16	16.0	8.8	5.7	
18	15.3	8.7	5.6	4.0
20	14.2	8.6	5.6	4.0
22	13.2	8.5	5.5	3.9
30	8.6	7.9	5.2	3.8
34	6.9	7.0	5.2	3.7
40	5.1	5.6	4.9	3.5
55	2.3	2.7	2.9	2.9
60		2.1	2.3	2.5
64				2.0

Main boom 53 m

Radius (m)	Fixed jib length in (m)			
	11	20	26	32
10	15.2			
16	14.6	8.0	5.3	3.8
20	13.4	7.9	5.2	3.7
24	11.5	7.7	5.0	3.6
26	10.3	7.6	5.0	3.6
28	9.3	7.5	4.9	3.5
30	8.4	7.5	4.9	3.5
34	6.8	6.8	4.8	3.4
36	6.1	6.3	4.8	3.4
44	4.0	4.5	4.4	3.3
60			2.2	2.3
62				2.1

Main boom 59 m

Radius (m)	Fixed jib length in (m)			
	11	14	17	20
10	12.8			
14	12.5	10.0	8.0	6.8
18	12.2	9.8	7.9	6.8
24	10.7	9.4	7.7	6.6
28	8.8	8.9	7.6	6.6
32	7.1	7.3	7.4	6.5
36	5.8	5.9	6.0	5.9
40	4.7	4.9	5.0	5.0
44	3.7	3.9	4.1	4.2
48	3.0	3.1	3.3	3.4
52	2.3	2.5	2.6	2.7
55		2.0	2.2	2.3

Capacities in metric tonnes with fixed jib (No. 0806.xx), 34 t counterweight + 17.5 t carbody counterweight. Above lift chart is for reference only. For actual lift duty and complete chart with all available configurations please refer to lift chart in operator's cab or manual.

Lift chart - fixed jib (No. 0806.xx)

TLT 11943069 - M236250

Offset 30°, swinging counterweight 90°

Main boom 20 m

Radius (m)	Fixed jib length in (m)			
	11	20	26	32
	t	t	t	t
19	15.4			
20	14.9			
22	14.1			
24	13.3	7.9		
26	12.2	7.6	5.7	
28	11.0	7.4	5.6	3.8
30	10.0	7.2	5.4	3.7
34		6.7	5.2	3.5
38		6.4	4.8	3.4
42			4.6	3.3
44			4.5	3.3
50				3.2

Main boom 26 m

Radius (m)	Fixed jib length in (m)			
	11	20	26	32
	t	t	t	t
17	16.4			
18	16.1			
20	15.3			
22	14.7	8.0		
24	13.4	7.9	5.9	
26	12.0	7.9	5.8	4.0
30	9.8	7.5	5.6	3.8
32	8.9	7.3	5.5	3.7
34	8.1	7.1	5.3	3.6
44		5.8	4.7	3.4
50			4.5	3.3
55				3.2

Main boom 29 m

Radius (m)	Fixed jib length in (m)			
	11	20	26	32
	t	t	t	t
17	16.2			
18	15.9			
20	15.2			
22	14.6	8.0		
24	13.3	7.9	5.8	
26	11.9	7.8	5.7	3.9
30	9.7	7.5	5.6	3.8
32	8.8	7.4	5.5	3.7
34	8.0	7.3	5.4	3.6
44		5.7	4.8	3.3
50			4.6	3.3
55				3.2

Main boom 32 m

Radius (m)	Fixed jib length in (m)			
	11	20	26	32
	t	t	t	t
16	16.5			
18	15.7			
20	15.2	8.2		
22	14.4	8.0		
26	11.8	7.8	5.7	4.0
32	8.7	7.5	5.5	3.7
38	6.6	7.0	5.2	3.5
42		6.0	5.0	3.4
46		5.1	4.8	3.3
48		4.7	4.7	3.3
55			3.8	3.2
60				3.2

Main boom 38 m

Radius (m)	Fixed jib length in (m)			
	11	20	26	32
	t	t	t	t
15	16.6			
16	16.3			
20	15.1	8.2		
24	13.0	7.9	5.8	4.0
30	9.4	7.7	5.6	3.8
36	7.0	7.2	5.4	3.6
42	5.3	5.8	5.2	3.5
44	4.8	5.4	5.1	3.4
46	4.4	4.9	5.0	3.4
55		3.3	3.6	3.3
60			2.9	3.1
65				2.5

Main boom 44 m

Radius (m)	Fixed jib length in (m)			
	11	20	26	32
	t	t	t	t
14	16.4			
16	15.9			
20	14.8	8.1		
24	12.8	7.8	5.6	3.9
28	10.1	7.7	5.5	3.8
34	7.4	7.2	5.4	3.7
40	5.5	6.2	5.2	3.5
48	3.8	4.3	4.6	3.4
50	3.4	3.9	4.2	3.3
55		3.1	3.4	3.2
60		2.4	2.7	2.9
65			2.4	2.3

Main boom 50 m

Radius (m)	Fixed jib length in (m)			
	11	20	26	32
	t	t	t	t
13	15.1			
14	15.0			
16	14.1			
18	13.4	8.1		
20	12.8	8.0	5.4	
22	12.0	7.8	5.3	
30	8.9	6.9	5.3	3.6
34	7.2	6.5	5.1	3.6
40	5.3	5.7	4.8	3.5
55	2.4	2.9	3.2	3.2
60		2.2	2.5	2.7
65				2.1

Main boom 53 m

Radius (m)	Fixed jib length in (m)			
	11	20	26	32
	t	t	t	t
13	14.2			
16	13.5			
20	12.3	7.8	5.0	
24	10.9	7.4	5.0	3.6
26	10.4	7.3	5.0	3.6
28	9.7	7.1	5.0	3.5
30	8.8	6.8	5.0	3.5
34	7.1	6.3	4.9	3.5
36	6.4	6.0	4.8	3.4
44	4.2	4.8	4.3	3.3
60		2.0	2.4	2.6
65				2.0

Main boom 59 m

Radius (m)	Fixed jib length in (m)			
	11	14	17	20
	t	t	t	t
12	12.7			
14	12.3	10.0		
18	11.8	9.9	8.0	6.9
24	10.5	9.3	7.9	6.9
28	9.2	8.6	7.6	6.9
32	7.5	7.7	7.1	6.4
36	6.1	6.3	6.5	6.0
40	4.9	5.1	5.4	5.3
44	3.9	4.2	4.4	4.6
48	3.1	3.3	3.5	3.7
52	2.4	2.6	2.8	3.0
55		2.2	2.4	2.5

Capacities in metric tonnes with fixed jib (No. 0806.xx), 34 t counterweight + 17.5 t carbody counterweight. Above lift chart is for reference only. For actual lift duty and complete chart with all available configurations please refer to lift chart in operator's cab or manual.

Notes

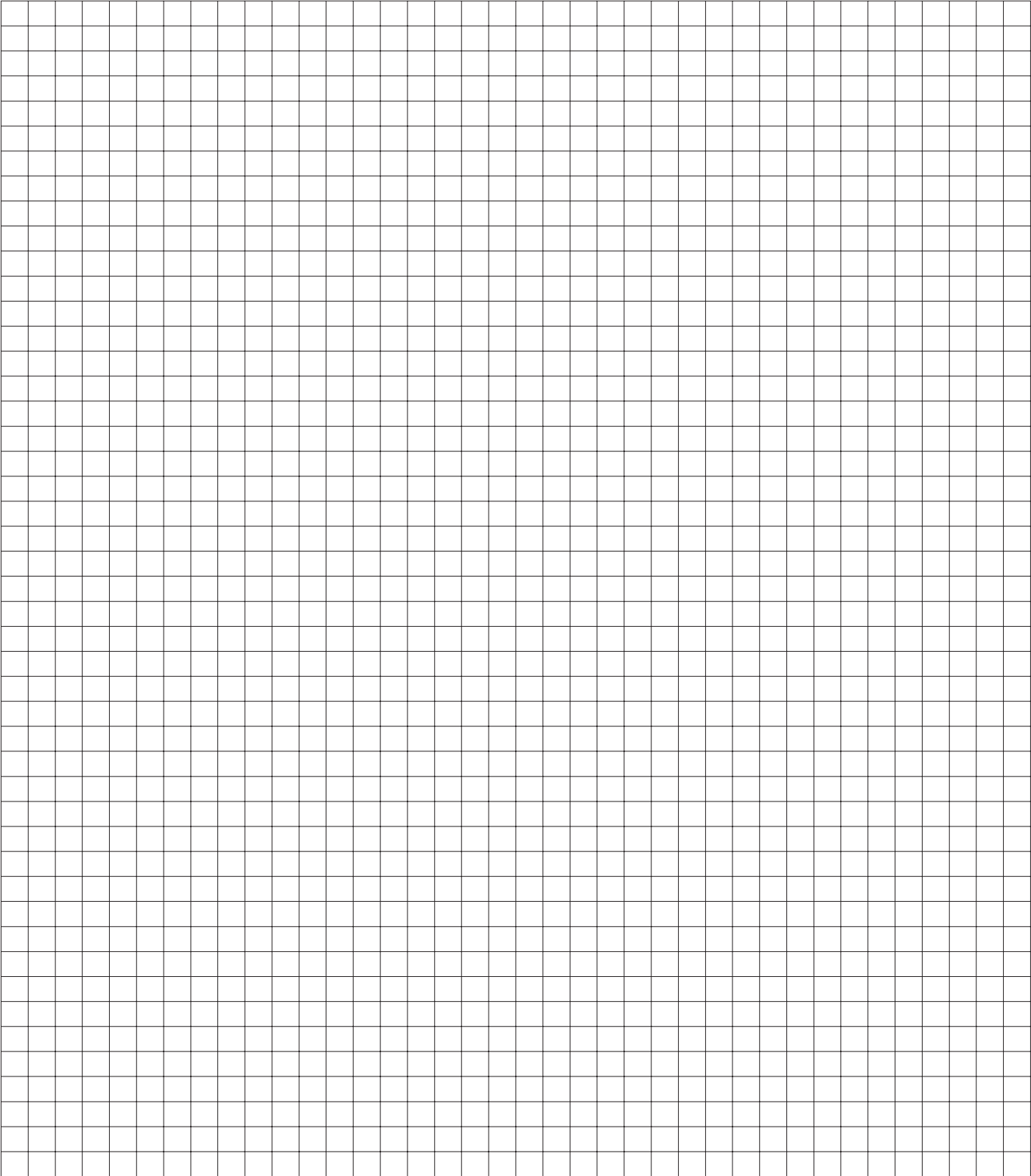

Notes

